



INSTALLATION AND OPERATING INSTRUCTIONS

2-jaw parallel gripper, electric
GEH6000IL

3-jaw concentric gripper, electric
GED6000IL

DDOC00212

THE KNOW-HOW FACTORY



Glossary

Term	Explanation
ActualPosition	Value of the current position of the product [1/100 mm]
Adjust	Starts the travel routing stored in the product to teach the BasePosition and WorkPosition.
BasePosition	Outer jaw position Depending on the application, this can be the base position or the work position.
ControlWord	Activation of the product Only one bit is permitted to be active in ControlWord. The value "0" is also permitted.
DeviceMode	Used to select gripping profiles as well as the additional help modes in the product.
Diagnosis	If an error occurs, outputs a diagnostic code that can be compared with the error list.
DIR	Direction/24 V DC cable connection Depending on the product, this signal is used to move the product.
Error	Fault
GND	Abbreviation for ground connection
GripForce	Setting the gripping force
Offset	Correction value
PositionTolerance	Tolerance range for TeachPosition, BasePosition and WorkPosition The value of the parameter acts in both directions.
ShiftPosition	ShiftPosition is a switching position between pre-positioning and gripper movement.
StatusWord	Summary of binary states of the product that can be returned as information to the control system.
Teach	Adoption of the ActualPosition as the TeachPosition.
TeachPosition	Taught-in workpiece position
Traversing routine	Defined procedure for movement of the gripper jaws
Travel path	Path on which the gripper jaws travel.
WorkpieceNo	Number of the selected workpiece recipe
WorkPosition	Inner jaw position Depending on the application, this can be the end position or the work position.
Workpiece loss detection	Function which, in case of workpiece loss, causes the product to move to the end position.

Content

1	Supporting documents	5
1.1	Notices and graphics in the installation and operating instructions	5
2	Safety notices	6
3	Proper use	8
4	Personnel qualification	9
4.1	Electricians	9
4.2	Specialists	9
4.3	Instructed personnel.....	9
4.4	Service personnel.....	9
4.5	Additional qualifications	9
5	Product description	10
5.1	Possible applications.....	10
5.2	Type plate	10
6	Functional description	11
6.1	LED status display	12
6.2	Control	12
6.3	Verified configuration examples	12
6.4	Self-locking mechanism	12
7	Technical data	13
8	Accessories/scope of delivery	13
9	Transportation/storage/preservation	13
10	Installation	14
10.1	Installing GEH6000IL	15
10.2	Installing GED6000IL	15
10.3	Safe shutoff for products with IO-Link.....	16
10.3.1	Safe shutoff for IO-Link grippers without an STO cable	16
10.3.2	Safe shutoff for IO-Link grippers with an STO cable	17
10.4	Installing the energy supply	18
10.4.1	Pin assignment	18
10.4.2	B12-Y-5IL Y-cable pin assignment.....	19
10.4.3	Pin assignment for products with an STO connection	20
10.5	Wiring.....	20
10.6	Static charge	21
10.7	Heat dissipation	21
10.8	Installing accessories	21
11	Commissioning	22
11.1	Process data	22
11.2	IODD Import	23
11.3	Handshake Data Transfer Method.....	23
11.4	Parameters	24
11.4.1	ControlWord.....	24
11.4.2	DeviceMode	25
11.4.3	Basic commands	26
11.4.4	WorkpieceNo	27
11.4.5	PositionTolerance	27
11.4.6	GripForce	28
11.4.7	DriveVelocity	28
11.4.8	BasePosition	28
11.4.9	ShiftPosition.....	29

- 11.4.10 TeachPosition.....29
- 11.4.11 WorkPosition.....29
- 11.4.12 StatusWord.....30
- 11.4.13 Diagnosis.....31
- 11.4.14 ActualPosition.....31
- 11.5 Cold start.....32
- 11.6 Minimum travel path.....32
- 11.7 Referencing by Homing.....33
 - 11.7.1 DeviceMode 10.....34
 - 11.7.2 DeviceMode 14.....34
 - 11.7.3 DeviceMode 16.....35
 - 11.7.4 DeviceMode 17.....36
- 11.8 Movement profiles GEH6xxxIL-03-B/GED6xxxIL-03-A.....37
 - 11.8.1 Positioning profiles.....38
 - 11.8.2 Force profiles.....39
- 11.9 Movement profiles GEH6xxxIL-31-B/GED6xxxIL-31-A.....45
 - 11.9.1 DeviceModes.....45
 - 11.9.2 Positioning profiles.....46
 - 11.9.3 Force profiles.....47
- 11.10 Interrupting the voltage supply.....53
- 11.11 Easy Startup.....53
- 11.12 Starting the data transfer.....54
- 11.13 Quickstart Basic Parameters.....55
- 11.14 Starting the gripping movement.....56
- 11.15 Repeated movements in the same direction.....56
- 11.16 Recipe examples.....57
 - 11.16.1 Save recipe.....57
 - 11.16.2 Loading a recipe.....58
- 12 Operation.....59
 - 12.1 Emergency release of GEH6000IL.....59
 - 12.2 Emergency release of GED6000IL.....60
- 13 Gripping force charts.....60
- 14 Error diagnosis.....61
- 15 Table with acyclic data (ISDU).....64
- 16 Maintenance.....69
 - 16.1 Testing the STO safety function.....70
- 17 Decommissioning/disposal.....71
- 18 RoHS declaration.....72
- 19 REACH declaration.....72
- 20 Declaration of Incorporation.....73
- 21 Declaration of Conformity.....74

1 Supporting documents

NOTICE



Read through the installation and operating instructions before installing or working with the product.

The installation and operating instructions contain important notes for your personal safety. They must be read and understood by all persons who work with or handle the product during any phase of the product lifetime.



The documents listed below are available for download on our website www.zimmer-group.com.

- Installation and operating instructions
 - Catalogs, drawings, CAD data, performance data
 - Information on accessories
 - Technical data sheets
 - General Terms and Conditions, including warranty information.
- ⇒ Only those documents currently available on the website are valid.

In these installation and operating instructions, "product" refers to the product designation on the title page!

1.1 Notices and graphics in the installation and operating instructions

DANGER



This notice warns of an imminent danger to the life and health of people. Ignoring these notices can lead to serious injury or even death.

- ▶ You absolutely must comply with the described measures for avoiding these dangers!
- ⇒ The warning symbols are assigned according to the type of danger.

WARNING



This notice warns of a situation that is potentially hazardous to personal health. Ignoring these notices can cause serious injury or damage to health.

- ▶ You absolutely must comply with the described measures for avoiding these dangers!
- ⇒ The warning symbols are assigned according to the type of danger.

CAUTION



This notice warns of a situation that is potentially hazardous to persons. Ignoring these notices can cause minor, reversible injuries.

- ▶ You absolutely must comply with the described measures for avoiding these dangers!
- ⇒ The warning symbols are assigned according to the type of danger.

NOTICE



This notice warns of possible material and environmental damage. Ignoring these notices can result in damage to the product or the environment.

- ▶ You absolutely must comply with the described measures for avoiding these dangers!
- ⇒ The warning symbols are assigned according to the type of danger.

INFORMATION



This category contains useful tips for handling the product efficiently. Failure to observe these tips will not result in damage to the product. This information does not include any information relevant to health or workplace safety.

2 Safety notices

CAUTION



Risk of injury and material damage in case of non-compliance

Installation, commissioning, maintenance and repairs may only be performed by qualified specialists in accordance with these installation and operating instructions.

The product is state-of-the-art.

The following are examples of situations in which the product may cause a hazard:

- The product is not properly installed, used or maintained.
- The product is not used for its designated purpose.
- The locally applicable regulations, laws, directives or guidelines are not observed.
- ▶ The product may only be used in accordance with these installation and operating instructions and the product's technical data. Any changes or additions to the intended use of the product, as well as modifications to the product, such as those in the following examples, require the written permission of the manufacturer:
 - Use of the product under extreme conditions, such as aggressive fluids or abrasive dusts
 - Additional drilled holes or threads
- ⇒ Zimmer GmbH shall accept no liability for any damage caused by improper use. The operator bears sole responsibility.
- ▶ Make sure that the power supply is disconnected before you mount, adjust, modify, maintain or repair the product.
- ▶ Whenever work is carried out on the product, make sure that the product cannot be actuated by mistake.
- ▶ Perform maintenance tasks, renovation work or attachment work outside of the machine's danger zone when possible.
- ▶ Do not reach into the operational range of the product.
- ▶ Always adhere to the required maintenance intervals.
- ▶ When using the product under extreme conditions, adjust the maintenance interval according to the degree of contamination.
- ▶ Check the completeness and tightening torques of all mounting screws.

WARNING**Risk of injury caused by suspended loads**

Improper handling of suspended loads can cause serious injury.

- ▶ Always keep an adequate safety distance from suspended loads.
- ▶ Do not stand or walk underneath suspended loads.

CAUTION**Notes and handling regulations for electrostatically sensitive components**

Electrostatically sensitive components are individual components, integrated circuits or assemblies that can be damaged by electrostatic fields or electrostatic discharge.

- ▶ When handling electrostatic components, make sure that persons, the work area and packaging are all fully grounded.
- ▶ Touch electronic components only in appropriately identified areas with conductive flooring and only if:
 - You are grounded by means of special bracelets.
 - You wear shoes that are suitable and approved for the discharge of electrostatic charges.
- ▶ Do not bring electronic assemblies into contact with plastics and parts of clothing that have plastic content.
- ▶ Store electronic assemblies on conductive underlays only.
- ▶ Do not install electronic assemblies in the vicinity of data back-up devices or monitors (monitor distance > 100 mm).
- ▶ Perform measurements on electronic assemblies only if:
 - The measuring instrument is grounded (e.g. via a ground conductor).
 - The measuring head is momentarily discharged before measuring with a floating measuring instrument.

3 Proper use

NOTICE



Material damage and malfunction in case of non-compliance

The product is only to be used in its original state with its original accessories, with no unauthorized changes and within the stipulated parameter limits and operating conditions.

Any other or secondary use is deemed improper.

- ▶ Operate the product only in compliance with the associated installation and operating instructions.
- ▶ Operate the product only when it is in a technical condition that corresponds to the guaranteed parameters and operating conditions.
- ⇒ Zimmer GmbH shall accept no liability for any damage caused by improper use. The operator bears sole responsibility.

- The product is designed exclusively for electric operation using a 24 V DC power supply.
- The product must always be mounted on materials that dissipate heat.
- The product is intended for industrial use.
- The product is to be used as intended in enclosed rooms for temporary gripping, handling and holding.
- The product is not suitable for clamping workpieces during a machining process.
- Direct contact with perishable goods/food is not permitted.

4 Personnel qualification

WARNING



Injuries and material damage due to inadequate qualification

If inadequately qualified personnel perform work on the product, this can cause serious injuries and significant material damage.

- ▶ All work on the product must be performed by qualified personnel.
- ▶ Before working with the product, read the document in its entirety and make sure that you have understood everything.
- ▶ Observe country-specific accident prevention regulations and the general safety notices.

The following qualifications are a prerequisite for performing various work on the product.

4.1 Electricians

Electricians are able to perform work on electrical systems, can recognize and avoid possible dangers and know the relevant standards and provisions due to their technical training, knowledge and experience.

4.2 Specialists

Specialists are able to perform the assigned work, can recognize and avoid possible dangers and know the relevant standards and provisions due to their technical training, knowledge and experience.

4.3 Instructed personnel

Instructed personnel have been trained by the operating company on the tasks and possible dangers of improper behavior.

4.4 Service personnel

Service personnel are able to perform the assigned work and can recognize and avoid possible dangers due to their technical training, knowledge and experience.

4.5 Additional qualifications

Persons who work with the product must be familiar with the valid safety regulations and laws as well as the standards, guidelines and laws listed in this document.

Personnel who work with the product must have facility-issued authorization to commission, program, configure, operate, maintain and also decommission this product.

5 Product description

CAUTION



Reduction of the gripping force can cause personal injury and material damage

When flexible components are gripped, the gripping force of the product is reduced.

Reduced gripping force can lead to personal injury or material damage, because the components that are being gripped can no longer be securely gripped and transported.

NOTICE



Malfunction in case of non-compliance

► Make sure that the setting of the gripping force and the selection of the gripper finger length are correct to prevent incorrect bracing of the gripper jaws.

5.1 Possible applications

Outside gripping

The product can be used for outside gripping.

MoveToWork command

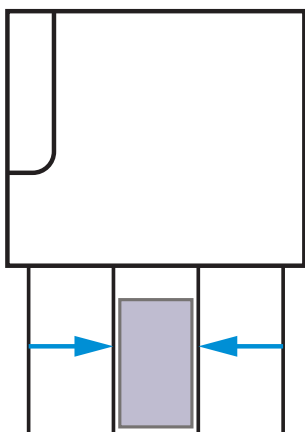

Inside gripping

The product can be used for inside gripping.

MoveToBase command

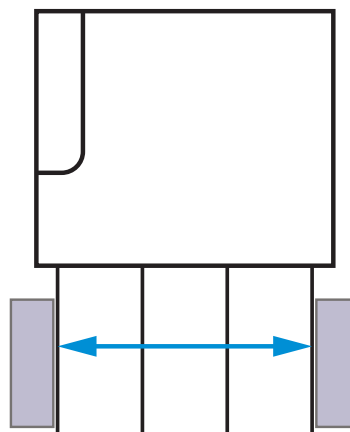

5.2 Type plate

A type plate is attached to the product.

The article number and confirmation number are shown on the type plate.

① Article number

② Confirmation number

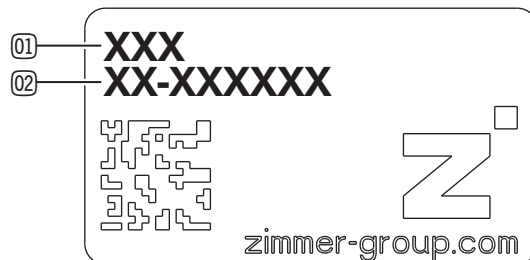

6 Functional description

The gripper jaws of the GEH6000IL series are arranged parallel to each other on two opposing guide rails and can be moved relative to each other.

The gripper jaws of the GED6000IL series are arranged parallel to each other on three guide rails offset at a 120° angle.

The force of the motor is transmitted by a worm drive. A pinion and a rack generate the movement of the gripper jaws and synchronize these movements.

Despite its small installation space, the product is suited for gripping a wide range of form-fit and frictional fit parts.

The product can be easily integrated into the existing control system.

The gripping force can be adapted optimally to the workpiece conditions via IO-Link.

GEH6000IL

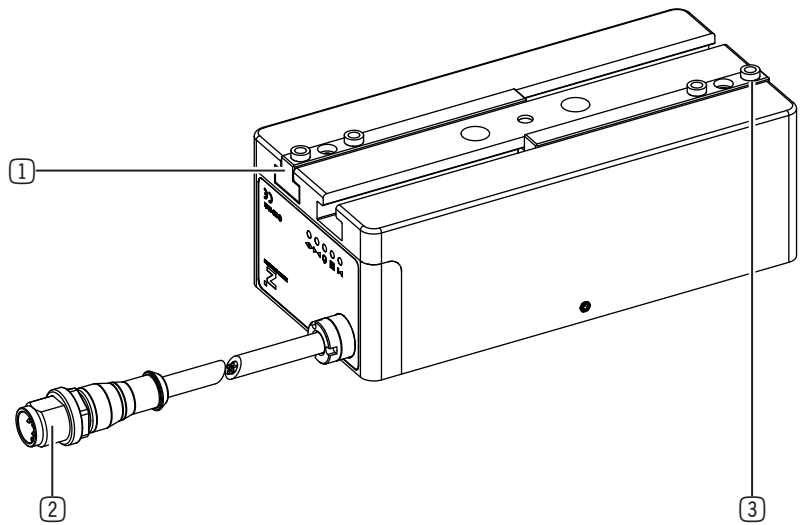

GED6000IL

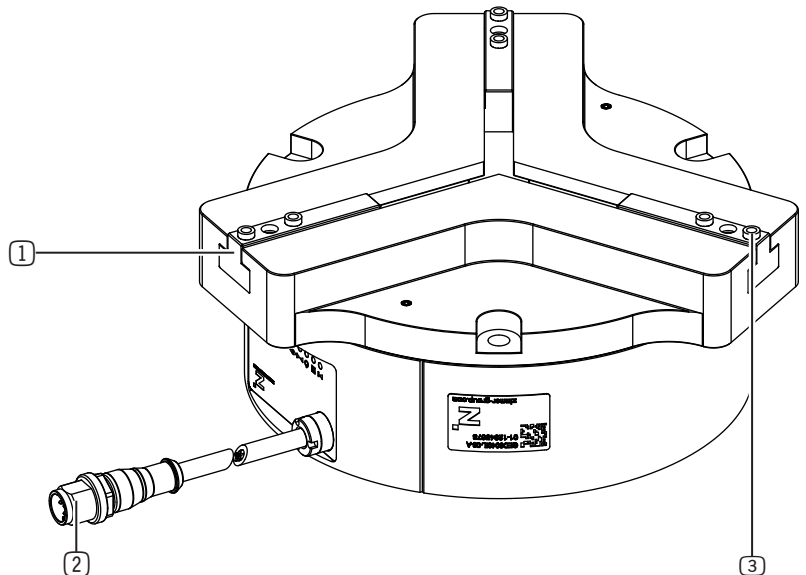

- ① T-slot guide
- ② Power supply
- ③ Removable centering sleeve

6.1 LED status display

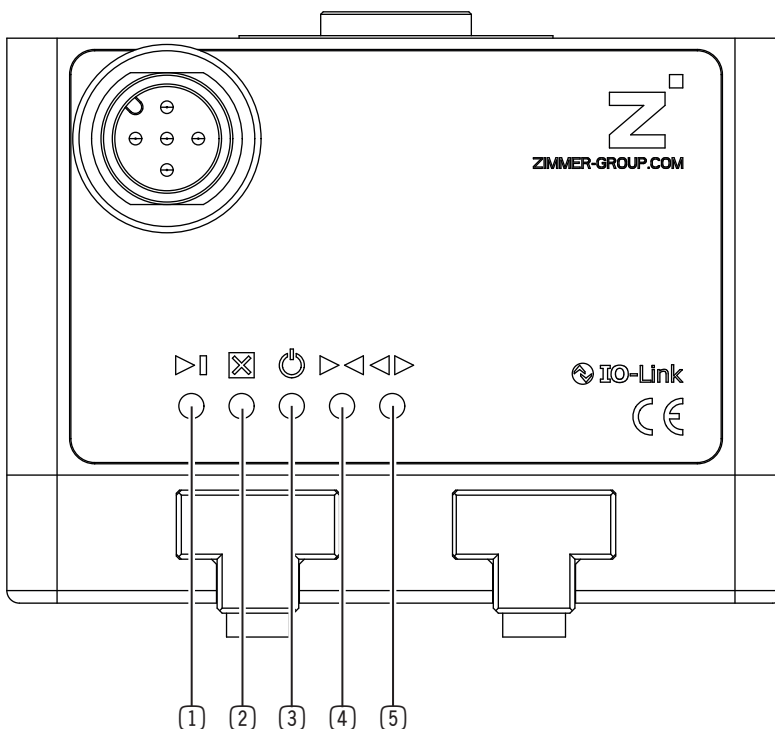

- ① TeachPosition
- ② Error
- ③ Power supply
- ④ WorkPosition
- ⑤ BasePosition

6.2 Control

INFORMATION



- ▶ You can find the information in the technical data sheet on our website.
- ▶ Please contact Customer Service if you have any questions.

6.3 Verified configuration examples

INFORMATION



- ▶ You can find the information on our website.
 - GEH6000IL series
 - GED6000IL series
- ▶ Please contact Customer Service if you have any questions.

6.4 Self-locking mechanism

INFORMATION



- The product has a mechanical self-locking mechanism to ensure that the workpiece remains held by the product in the event of power supply loss or failure (e.g. an emergency stop).
- The self-locking mechanism is not available for the products GEH60xxIL-31-B and GED60xxIL-31-A.
- ▶ Please contact Customer Service if you have any questions.

7 Technical data

INFORMATION



- ▶ You can find the information in the technical data sheet on our website.
- ▶ This data varies within the series, depending on the specific design.
- ▶ Please contact Customer Service if you have any questions.

8 Accessories/scope of delivery

INFORMATION



- ▶ If any accessories not sold or authorized by Zimmer GmbH are used, the function of the product cannot be guaranteed. Zimmer GmbH accessories are specifically tailored to the individual products.
- ▶ For optional accessories and those included in the scope of delivery, refer to our website.

9 Transportation/storage/preservation

- ▶ Transport and storage of the product must be done only with the original packaging.
- ▶ If the product has already been installed on the superordinate machine unit, care must be taken during transport to ensure that no unexpected movements can occur.
 - ▶ Before commissioning the product and after transport, check all power and communication connections as well as all mechanical connections.
- ▶ If the product is stored for an extended period, the following points are to be observed:
 - ▶ Keep the storage location as dust-free and dry as possible.
 - ▶ Avoid temperature fluctuations.
 - ▶ Avoid wind/drafts/water condensation formation.
 - ▶ Pack the product and do not expose it to direct sunlight during storage.
- ▶ Clean all components. There must be no soiling left on the components.
- ▶ Visually inspect all components.
- ▶ Remove all foreign substances.
- ▶ Properly remove potential corrosion spots.
- ▶ Close electrical connections using suitable covers.

10 Installation

WARNING



Risk of injury due to uncontrolled movements

Risk of injury in case of unexpected movement of the machine or system into which the product is to be installed.

- ▶ Switch off the energy supply of the machine before any work.
- ▶ Secure the power supply against being switched on unintentionally.
- ▶ Check the machine for any residual energy that may be present.

CAUTION



Risk of injury due to uncontrolled movements

Risk of injury in the event of uncontrolled movement of the product when the power supply is connected.

- ▶ Switch off the power supply to the machine before carrying out any work.
- ▶ Secure the power supply against being switched on unintentionally.
- ▶ Check the machine for any residual energy that may be present.

NOTICE



Non-compliance may result in material damage.

Installation may only be carried out by qualified personnel in accordance with these installation and operating instructions.

- ▶ Switch off the power supply before any assembly, installation or maintenance work.

Assembly requirements

Permissible unevenness [mm]	0,03
Strength class of the mounting screws	8.8

INFORMATION



Further installation information:

- The mounting screws are not included in the scope of delivery.

- ▶ Make sure that the mounting surface of the product and connection structure are clean (product grounding).
- ▶ Install the product on an appropriate mounting surface in accordance with the flatness specifications.
- ▶ Make sure that the mounting piece is sufficiently rigid.
- ▶ Please note the permitted tightening torques of the mounting screws at www.zimmer-group.com/en/td.

10.1 Installing GEH6000IL

The product can be installed from multiple sides.

- ▶ Insert the straight pins or the centering sleeves into the provided fits on the product.
- The type of positioning varies within the series.
- ▶ Use the centering sleeves or straight pins to position the product on the mounting piece.
- ▶ Mount the product on the mounting piece using the appropriate mounting screws.

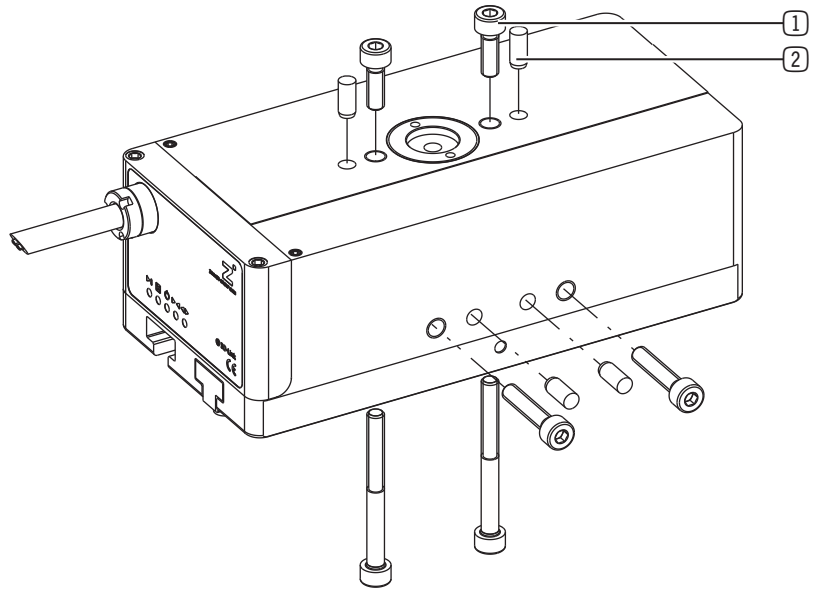

- ① Mounting screw
- ② Straight pins

10.2 Installing GED6000IL

The product can be installed from multiple sides.

- ▶ Insert the straight pins or the centering sleeves into the provided fits on the product.
- The type of positioning varies within the series.
- ▶ Use the centering sleeves or straight pins to position the product on the mounting piece.
- ▶ Mount the product on the mounting piece using the appropriate mounting screws.

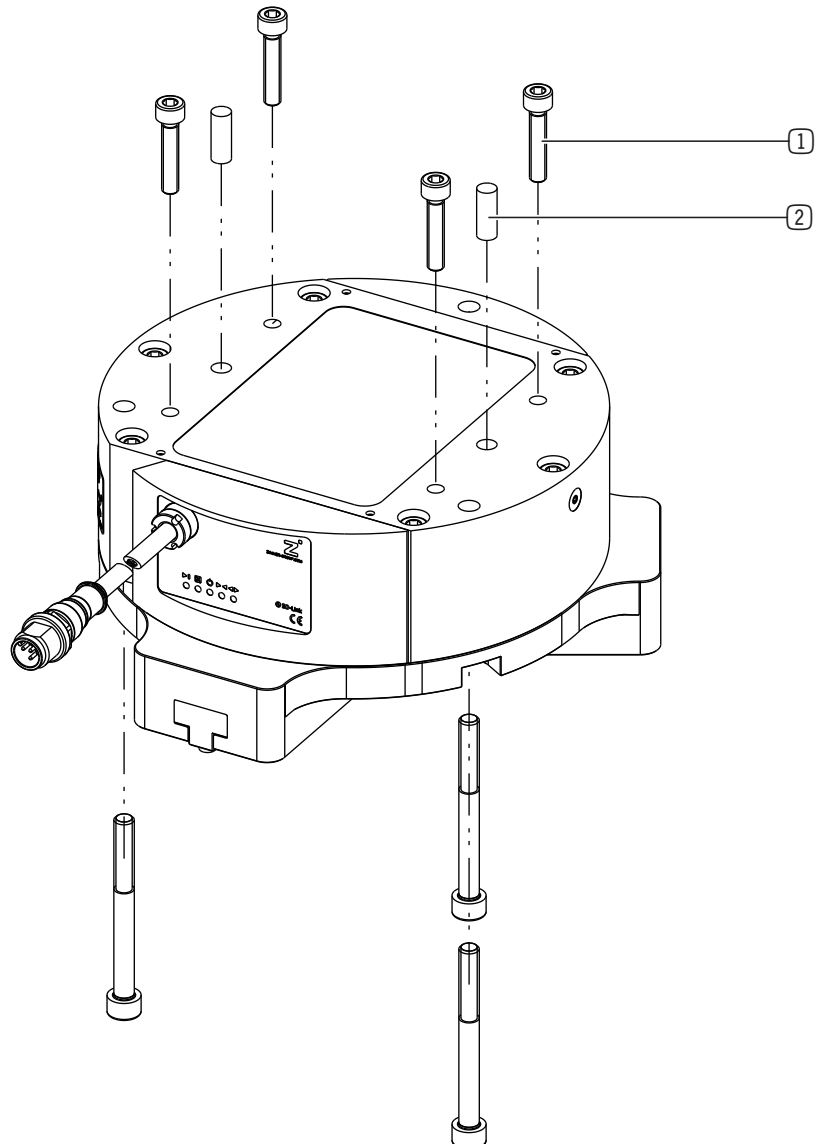

- ① Mounting screw
- ② Centering Disc

10.3 Safe shutoff for products with IO-Link

10.3.1 Safe shutoff for IO-Link grippers without an STO cable

INFORMATION



For safe shutoff for IO-Link products, two contactors are switched in series with one auxiliary contact each. Here, the auxiliary contacts monitor the status of the contactors. If one contactor does not switch, the second contactor ensures safety. The malfunction can still be detected using the contacts.

The following figure shows the example of a circuit through which the IO-Link master cannot conduct the actuator current of the product.

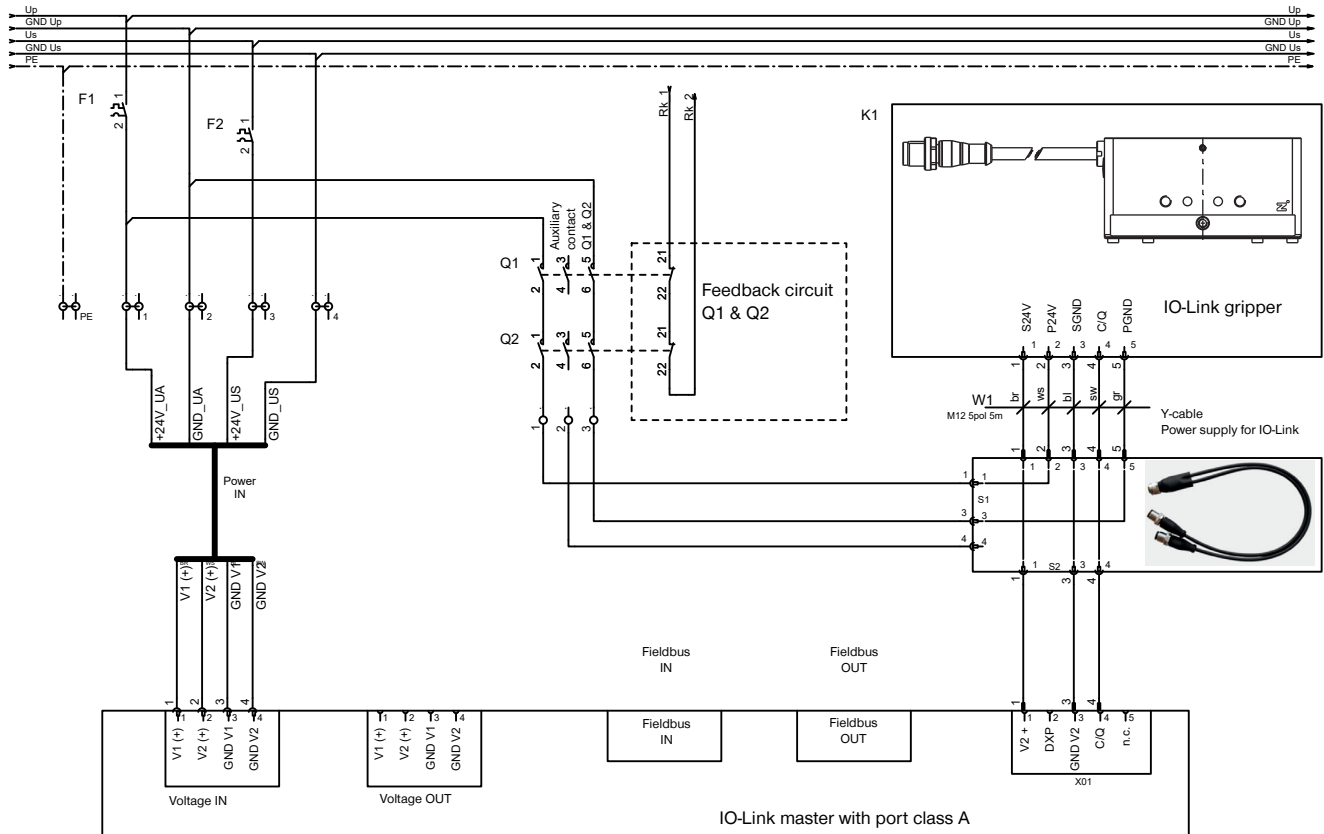

NOTICE



Without an externally fed voltage supply, the motor of the product cannot carry out an active movement and thus cannot carry out a hazardous movement.

There is no galvanic separation between the two voltage supplies (signal and power). There is a low-voltage connection via the ground (GND).

Because of the self-locking mechanism, the product remains in the last approached position, even if no voltage is supplied.

10.3.2 Safe shutoff for IO-Link grippers with an STO cable

INFORMATION



In order to put the gripper into a safe STO status, the STO can be shut off exclusively or together with the power supply. The STO switching unit, e.g. safety PLC or PNOZ, always switches Pin 1 and Pin 4 synchronously (see section "Installing the power supply").

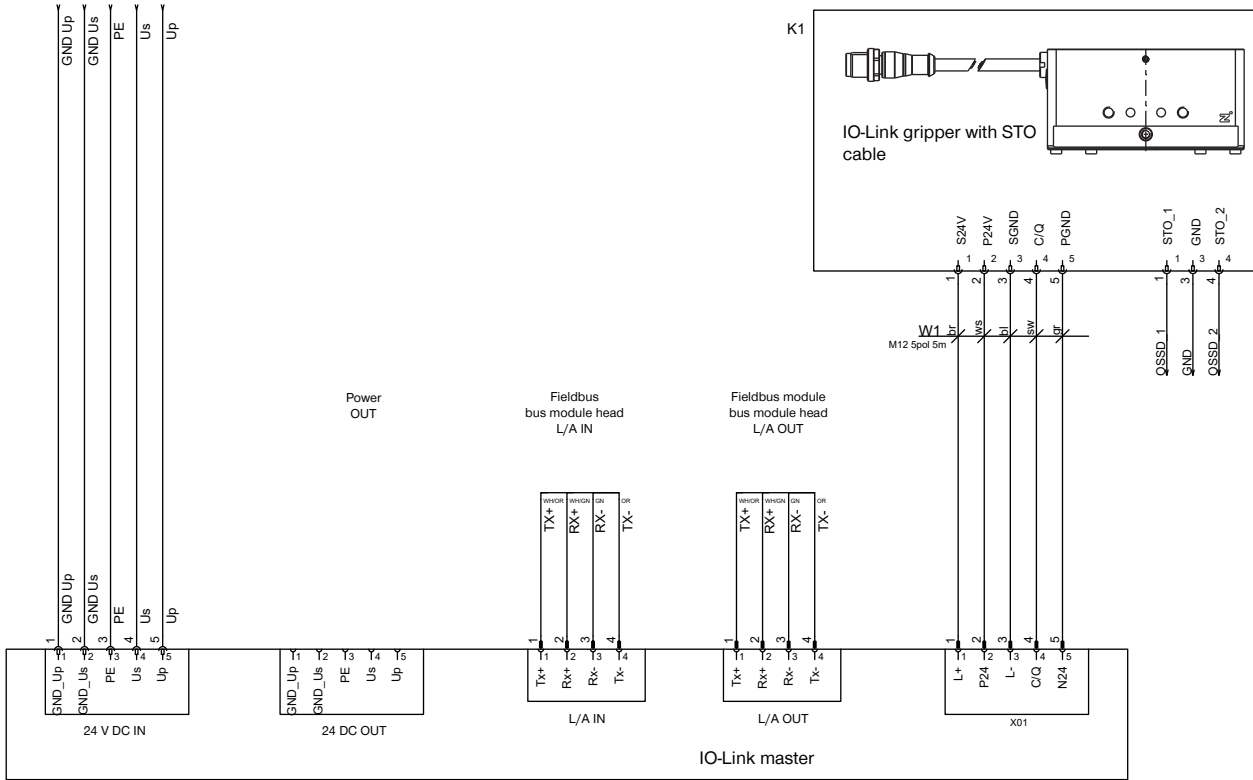

INFORMATION



- ▶ Connect the STO signals to the safety relay as follows in order to detect an error in the external switchgear in the form of an electrically conductive bridge:
 - STO_1 to OSSD_1
 - STO_2 to OSSD_2

INFORMATION



The self-locking products come to a stop immediately. Despite a torque-free motor, no more hazardous movements can occur on the product.

10.4 Installing the energy supply

NOTICE



Destruction of the product

In the event that the polarity of the product is reversed, the IO-Link chip may be destroyed as a result of the duration of current of the C/Q (pin 4) being too long.

- ▶ Connect the product according to its assignment diagram.

NOTICE



Non-compliance may result in material damage.

The cable mounted on the product can be subjected to a torsional angle of +50°.

- ▶ Do not route the cable so that it is strained.
 - ▶ You must meet the minimum bending radius of 10x the outer diameter.
 - ▶ Secure free-hanging cables to prevent excessive motion loads or pinching.
 - ▶ The contacts of the energy supply must be dry, clean and undamaged at all times.
- ⇒ Damage to the contacts can result in malfunction of the product.

- ▶ Connect the power supply cable to the control system of the product.

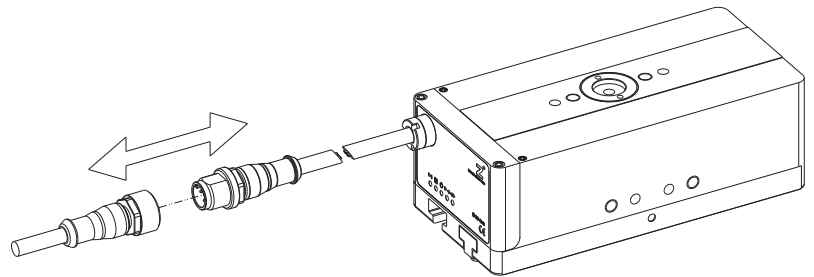

10.4.1 Pin assignment

INFORMATION



IO-Link Version 1.1.

Transmission speed: COM3 (230.4 kBaud).

INFORMATION



- ▶ Note the deviation from the IO-Link port class B specification: There is no electrical isolation between the actuator and sensor voltage in the product.

⇒ An optional B12 Y-cable allows electrical isolation from the perspective of the IO-Link master.

pin	Color	Function	Explanation
1	Brown	24 V DC sensor	24 V DC supply voltage for IO-Link communication
2	White	PWR actuator	24 V DC supply voltage for actuator
3	Blue	GND sensor	0 V DC supply voltage for IO-Link communication
4	Black	C/Q	IO-Link communication
5	Gray	GND actuator	0 V DC actuator supply voltage

M12 5-pin plug

- ▶ Connect the product to the IO-Link master.
- ▶ Ensure the proper voltage supply.
- ▶ Configure the IO-Link master, see the "Commissioning" section.

10.4.2 B12-Y-5IL Y-cable pin assignment

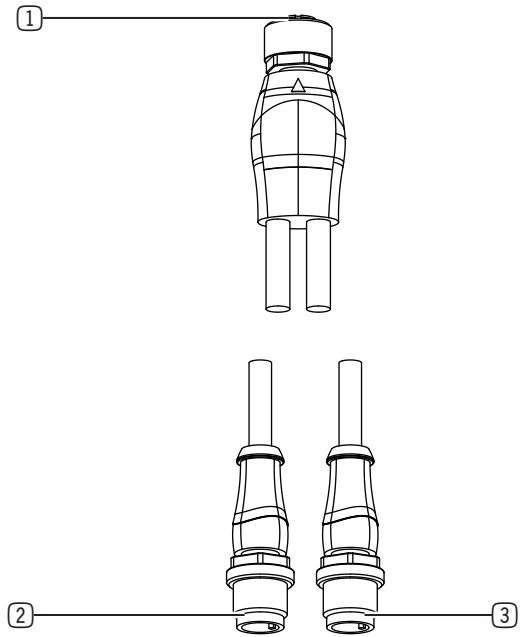

- ① Socket
- ② Plug 1
- ③ Plug 2

pin	Color	Function	Explanation
1	Brown	24 V DC sensor	24 V DC supply voltage for IO-Link communication
2	White	PWR actuator	24 V DC supply voltage for actuator
3	Blue	GND sensor	0 V DC supply voltage for IO-Link communication
4	Black	C/Q	IO-Link communication
5	Gray	GND actuator	0 V DC supply voltage for actuator

M12 5-pin socket

pin	Color	Function	Explanation
1	Brown	PWR actuator	24 V DC supply voltage for actuator
3	Blue	GND actuator	0 V DC supply voltage for actuator
4	Black	-	-

M12 5-pin plug 1

pin	Color	Function	Explanation
1	Brown	24 V DC sensor	24 V DC supply voltage for IO-Link communication
3	Blue	GND sensor	0 V DC supply voltage for IO-Link communication
4	Black	C/Q	IO-Link communication

M12 5-pin plug 2

10.4.3 Pin assignment for products with an STO connection

pin	Color	Function	Explanation
1	Brown	Sensor 24 V DC STO-1	STO1 signal from external safety switch device
3	Blue	GND	Ground potential
4	Black	24 V DC STO-2 signal	STO2 signal from external safety switch device

M8 3-pin plug

- ▶ Carry out the listed steps for wiring the product to the IO-Link.
- ▶ Wire the product to the STO line.
- ▶ Connect the STO1 and STO2 signals at the same time using the identical voltage level (0 V or 24 V).
- ⇒ Failure to observe this will result in the product switching to a safe state and signaling = 0x0100 at the diagnostics.
- ⇒ The product cannot be moved any more without a cold boot because a fatal error is present.

10.5 Wiring

The product is in a safe state if both STO signals have the status of "FALSE" (0 V). The STO circuit in the product is interrupted.

- ▶ To move the product again, set both STO signals to the status of "TRUE" (24 V).
- ⇒ The diagnostics of the product change to 0x0001 (Motor switched off) if the wiring is correct.
- ▶ Switch on the motor.
- ▶ Select the desired DeviceMode and transfer it.
- ▶ Start the movement.

10.6 Static charge

NOTICE



Non-compliance may result in material damage.

Grounding the product is recommended if ESD sensitive parts come into contact with the product.
Grounding is also recommended in applications that require high EMC shielding.

The movement of the gripper jaws creates low voltages as a result of static charging. These charges cannot be dissipated if the product is mounted on an insulating surface and if discharge is also not possible through the workpiece.

NOTICE



► Pay attention to the functional ground via the connection point.

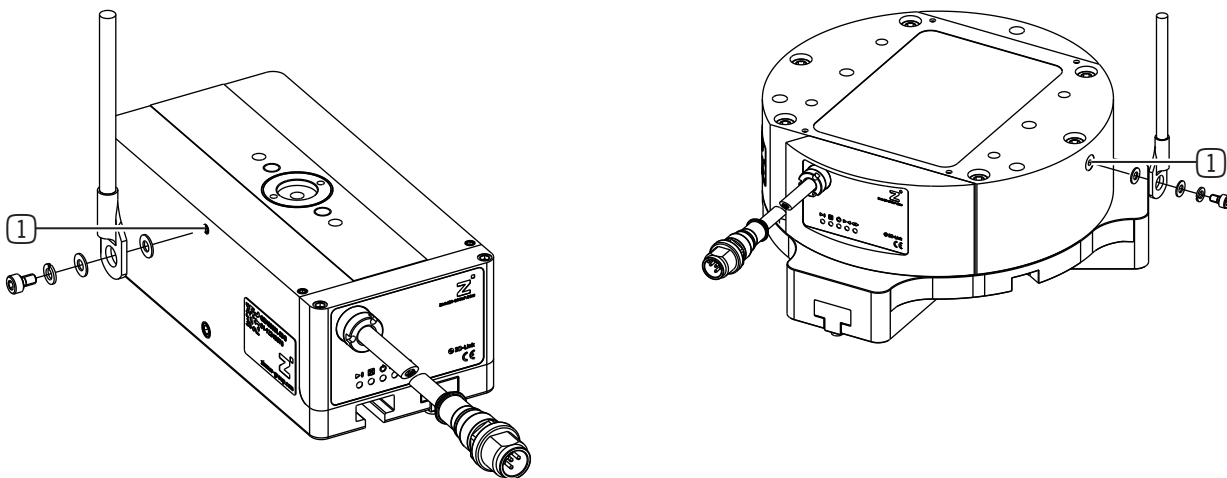

① Connection point

10.7 Heat dissipation

In the event of high ambient temperatures, the product must be installed on heat-dissipating materials.

If the product is operated under very high ambient temperatures and with fast clock cycles on an ongoing basis, this might reduce its service life.

INFORMATION



► The cycle time must therefore be reduced as the temperature increases.

10.8 Installing accessories

NOTICE



Non-compliance may result in material damage.

- Before installing an accessory, make sure it is suitable for use with the selected variant.
- You can find information on our website.
- Please contact Customer Service if you have any questions.

11 Commissioning

11.1 Process data

There is an option to control the product only with the process data that is transmitted in each cycle.

INFORMATION



The terms process data input and output are to be understood from the perspective of the gripper.

Process data input	Data type
ControlWord	UINT16
DeviceMode	UINT8
WorkpieceNo	UINT8
Reserve	UINT8
PositionTolerance	UINT8
GripForce	UINT8
DriveVelocity	UINT8
BasePosition	UINT16
ShiftPosition	UINT16
TeachPosition	UINT16
WorkPosition	UINT16

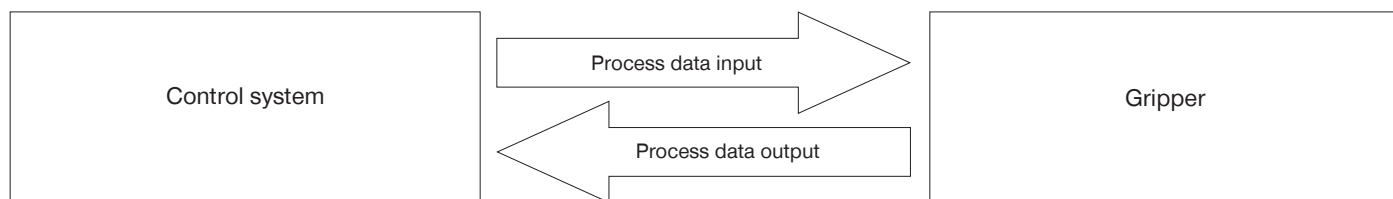

Process data output	Data type
StatusWord	UINT16
Diagnosis	UINT16
ActualPosition	UINT16

11.2 IODD Import

- ▶ Import the IODD (device description) into the control system.
 - ▶ Go to our website.
 - ▶ Select the desired product.
 - ▶ Download the corresponding .zip file via the Download IODD link.
- ⇒ You will need the .zip file for import into the control system.
- ⇒ As soon as the hardware configuration is complete and the IO-Link connection to the product is established, data will be displayed in the process input data.
- ⇒ Some control systems demand a byte swap to bring this process data into a logical sequence.
- ▶ Look at bit 6 (GripperPLCActive) in the StatusWord to determine whether a byte swap is necessary.
 - ▶ Determine whether bit 6 is active in the first or second byte of the StatusWord.
 - ⇒ Bit 6 is active in the first byte: The bytes already have the correct sequence.
 - ▶ Continue with the commissioning.
 - ⇒ Bit 6 is active in the second byte.
 - ▶ Apply a byte swap, refer to the "StatusWord" section.

INFORMATION



The product is controlled via IO-Link by means of the cyclical process data as well as the acyclic service data with a cycle time of 10 ms.

- ▶ It is mandatory to verify the process data!

11.3 Handshake Data Transfer Method

The handshake method makes it possible to transfer the process data about the product. All process data described in the following sections must be transferred with the handshake.

- ▶ Send the ControlWord = 0x0001 to the product.
- ⇒ The data transfer was started.
- ▶ Check the response of the product by using Statusbit 12 = TRUE (data transfer OK).
- ▶ Send the ControlWord = 0x0000 to stop the data transfer.
- ⇒ The data transmission is complete when the product sends back Statusbit 12 = DataTransferOK = FALSE.

INFORMATION



- ▶ For examples, refer to the "Quickstart Basic Parameters" section.

11.4 Parameters

11.4.1 ControlWord

NOTICE



In the ControlWord parameter, only one single bit or the value 0 may be set at a time. Only the values listed in the following table are valid.

Parameter	Decimal value	Hexadecimal value
DataTransfer	1	0x0001
WritePDU	2	0x0002
ResetDirectionFlag	4	0x0004
Teach	8	0x0008
MoveToBase	256	0x0100
MoveToWork	512	0x0200
JogToWork +	1024	0x0400
JogToBase -	2048	0x0800

Name	ControlWord
Data format	UINT16
Permission	Write
Transfer	Cyclical
Value range	0 - 65535

	Bit 15	Bit 14	Bit 13	Bit 12	Bit 11	Bit 10	Bit 9	Bit 8
Byte 1	-	-	-	-	JogToBase	JogToWork	MoveToWork	MoveToBase
	Bit 7	Bit 6	Bit 5	Bit 4	Bit 3	Bit 2	Bit 1	Bit 0
Byte 2	-	-	-	-	Teach	ResetDirectionFlag	WritePDU	DataTransfer

Bit 0: DataTransfer

Setting this bit causes the product to acquire the data transmitted in the process data ("WorkpieceNo" = 0) or the data stored in the workpiece data ("WorkpieceNo" = 1 to 32) as the active data set.

Setting this bit tells the product that the direction flag needs to be reset. This function is available starting from Application Firmware Version SWA000059_000, see Chapter "Table of acyclic data (ISDU)" Index 0x0017.

Bit 1: WritePDU

Setting this bit tells the product that it should write the current process data to the selected workpiece recipe.

Bit 2: ResetDirectionFlag

Setting this bit tells the product that the direction flag needs to be reset. This makes a repeated movement to a position possible. This is logical during a switchover of workpiece recipes.

NOTICE



Non-compliance may result in material damage.

▶ Please note that the product can be damaged from overheating due to repeated, prompt movement to the end stop or with a gripped workpiece.

Bit 3: Teach

Setting this bit tells the product to save the current position as the TeachPosition in the selected WorkpieceNo. This only works if there is no "0" that is transmitted in the workpiece number.

Bit 8: MoveToBase

Setting this bit tells the product to move toward the BasePosition.

Bit 9: MoveToWork

Setting this bit tells the product to move toward the WorkPosition.

Bit 10: JogToWork

Setting this bit in the ControlWord puts the product in jog mode and slowly moves it toward the WorkPosition. If the bit is reset, the product stops.

Bit 11: JogToBase

Setting this bit in the ControlWord puts the product in jog mode and slowly moves it toward the BasePosition. If the bit is reset, the product stops.

11.4.2 DeviceMode

The DeviceMode parameter can be used to control the movement of the product and the adaptation to the workpiece. For this purpose, various basic modes and movement profiles are available.

Name	DeviceMode
Data format	UINT8
Permission	Write
Transfer	Cyclical
Value range	0 to 255

INFORMATION



► Note that different operating modes are available depending on the product, see section "Movement profiles for the GEH6xxxIL-03-B/GED6xxxIL-03-A" and "Movement profiles for the GEH6xxxIL-31-B/GED6xxxIL-31-A."

11.4.3 Basic commands

These modes control the basic product actions.

DeviceMode	Action	ControlWord
0	Not sent to the motor control system.	dc
1	Idle	0x0001
2	Gripper reset	0x0001
3	Switch on the motor.	0x0001
5	Switch off motor/stop gripping movement.	0x0001
11	Activate jog mode.	0x0400/0x0800

1 Idle

In this mode, no movement can be carried out (idle command).

2 Gripper reset

A reset of the motor controller is triggered in this mode.

3 Switch on the motor control

The motor control is switched on and the output stage is activated. The movement is started after a move command is issued.

5 Switch off the motor control

The motor control is switched off and the output stage is activated. All movements of the product are stopped.

11 Jog operation

Product is in jog mode and moves slowly in the selected direction as long as the respective bit is active in the ControlWord. Revoking the move command results in an immediate standstill of the product. This mode can be used for setting up the gripper positions.

11.4.4 WorkpieceNo

The workpiece number is used for selecting the previously stored workpiece data, as well as for selecting the "WorkpieceNo" data record in which the current process data is stored.

The "WorkpieceNo" data set enables individual workpieces to be taught in to the product very quickly.

With a value > 0 and data acquisition via a handshake, the corresponding workpiece recipe is loaded in the product.

INFORMATION



For example codes, refer to the "Quickstart Basic Parameters" and "Recipe Examples" sections.

Name	WorkpieceNo
Data format	UINT8
Permission	Write
Transfer	Cyclical
Value range	0 - 32

11.4.5 PositionTolerance

Used to configure the position tolerance with a resolution of 0.01 mm.

Thus, the value range of 0 to 255 can be used to set a maximum tolerance of 2.55 mm in both directions.

INFORMATION



Example:
For TeachPosition 1500 (15 mm), PositionTolerance 150 lets you configure a tolerance of 1.5 mm in both directions.

This means that the TeachPosition range starts at 13.5 mm and goes all the way up to 16.5 mm.

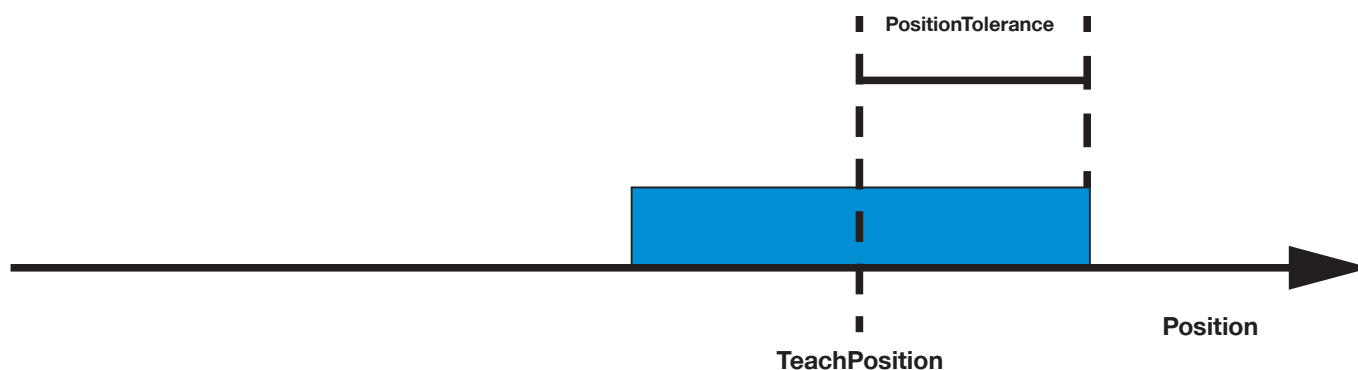

Name	PositionTolerance
Data format	UINT8
Permission	Write
Transfer	Cyclical
Value range	0 to 255

11.4.6 GripForce

The product can use various gripping forces for an optimized process sequence. The gripping force is indicated as a percent from the minimum to the maximum gripping force. The user can transmit the required gripping force in increments of 1%.

Name	GripForce
Data format	UINT8
Permission	Write
Transfer	Cyclical
Value range	1 to 100 %

NOTICE



Material damage and malfunction in case of non-compliance

For the products GEH6000IL-03 and GED6000IL-03, operation up to 130% gripping force is possible. During this process, the product switches to a higher maximum permitted peak current.

⇒ Depending on the shape of the gripper fingers, the product may become jammed.

11.4.7 DriveVelocity

The product can work at various movement speeds for an optimized process sequence.

This parameter determines the movement speed of the product in both directions in PositionProfile.

In the other modes, this parameter determines the movement speed from the workpiece.

In PrePosition-ForceProfile mode, it determines the movement speed to the switching position.

The positioning speed is specified as a percentage value (1% to 100%). The product converts this information to its maximum movement speed.

INFORMATION



Example:

To set a movement speed of 75%, a value of 75 (DriveVelocity = 75) must be transmitted.

Name	DriveVelocity
Data format	UINT8
Permission	Write
Transfer	Cyclical
Value range	1 to 100 %

11.4.8 BasePosition

The BasePosition defines the target position in the MoveToBase direction. It must always be less than the ShiftPosition.

The product verifies this and, if necessary, displays an error message.

If the current position of the product within the tolerance range is in the vicinity of the BasePosition, bit 8 is set in the StatusWord.

Moving beyond this position is also possible.

► Select an appropriately large distance to the mechanical end stop.

Name	BasePosition
Data format	UINT16
Permission	Write
Transfer	Cyclical
Value range	0.75 to max. jaw stroke of the product + 0.75 mm

11.4.9 ShiftPosition

The ShiftPosition must always be larger than the BasePosition and smaller than the WorkPosition.

The product verifies this and, if necessary, displays an error message.

The input is on a scale of 1/100 mm (Example: 1000 = 10 mm).

Name	ShiftPosition
Data format	UINT16
Permission	Write
Transfer	Cyclical
Value range	0.75 to max. jaw stroke of the product + 0.75 mm

11.4.10 TeachPosition

The TeachPosition defines the target position of the workpiece and its use is optional.

If the current position of the product within the tolerance range is around the TeachPosition, bit 9 is set in the Status.

The size of the tolerance range is defined with the parameter PositionTolerance.

This is entered at a scale of 1/100 mm (example: 1500 = 15 mm).

Name	TeachPosition
Data format	UINT16
Permission	Write
Transfer	Cyclical
Value range	0.75 to max. jaw stroke of the product + 0.75 mm

11.4.11 WorkPosition

The WorkPosition defines the maximum travel path of the product and has to be greater than the ShiftPosition.

If the current position of the product is within the tolerance range of the WorkPosition, bit 10 is set in the status.

In the PositionProfile, this position is precisely approached because the product is in positioning mode.

In DeviceMode 60 and 80, the product is stopped, starting from this position. The product moves past the WorkPosition. A maximum of 2 mm, depending on the movement speed and gripper finger dimensions.

Name	WorkPosition
Data format	UINT16
Permission	Write
Transfer	Cyclical
Value range	0.75 to max. jaw stroke of the product + 0.75 mm

Outputs: Process data from the product to the IO-Link master

11.4.12 StatusWord

StatusWord structure:

	Bit 15	Bit 14	Bit 13	Bit 12	Bit 11	Bit 10	Bit 9	Bit 8
Byte 1	Error	ControlWord 0x0200	ControlWord 0x0100	DataTransferOK	Undefined- Position	WorkPosition	TeachPosition	BasePosition
	Bit 7	Bit 6	Bit 5	Bit 4	Bit 3	Bit 2	Bit 1	Bit 0
Byte 0	-	Gripper- PLCActive	JogWork- Active +	JogBase- Active -	Movement- Complete	InMotion	MotorON	HomingPo- sition OK

Bit 0: HomingPosition OK

The product has its reference. This bit is mandatory. If the bit is FALSE, a reference run must be carried out. Refer to "Referencing by Homing" section.

Bit 1: MotorON

This bit becomes TRUE when the motor is switched on.

Bit 2: InMotion

This bit is active during the run.

Bit 3: MovementComplete

This bit is active after the movement is complete.

Bit 4: JogBaseActive -

Confirmation during the Jog run in the direction of BasePosition.

Bit 5: JogWorkActive +

Confirmation during the Jog run in the direction of WorkPosition.

Bit 6: GripperPLCActive

Active as soon as the product has booted up after the cold boot. This bit can be used to verify a "byte swap."

Bit 8: BasePosition

Active if the product is set to BasePosition.

Bit 9: TeachPosition

Active if the product is set to TeachPosition.

Bit 10: WorkPosition

Active if the product is set to WorkPosition.

Bit 11: UndefinedPosition

Active if the product is not set to TeachPosition, WorkPosition or BasePosition.

Bit 12: DataTransferOK

This bit is used for data transmission using the handshake. Active as soon as the product has taken over the data using the parameter ControlWord = 1 (decimal).

Bit 13: ControlWord 0x0100

This bit is a direction flag. Active if the last motion task was carried out toward BasePosition.

Bit 14: ControlWord 0x0200

This bit is a direction flag. Active if the last motion task was carried out toward WorkPosition.

Bit 15: Error

Active if the product has an active error. The error message can be determined using Diagnosis.

11.4.13 Diagnosis

The value returned in Diagnosis corresponds to the error code (see "Error Diagnosis" section).

Name	Diagnosis
Data format	UINT16
Permission	Write
Transfer	Cyclical
Value range	0 - 65535

11.4.14 ActualPosition

ActualPosition corresponds to the current position of the gripper jaws relative to the full stroke.

The value is specified with a resolution of 0.01 mm.

The values can move between the BasePosition (minimum values) and the WorkPosition (maximum values).

With the position measuring system, it is possible to achieve a position accuracy of ± 0.05 mm.

Name	ActualPosition
Data format	UINT16
Permission	Read
Transfer	Cyclical
Value range	0 to max. jaw stroke of the product

INFORMATION



- ▶ Use the StatusWord to check whether a workpiece has been gripped correctly.
- The position measurement resolution is 0.01 mm.
- The position measurement accuracy is 0.1 mm.
- ▶ During commissioning, be aware of fluctuations around the exact value if you use ActualPosition to detect the workpiece.

11.5 Cold start

For proper function, Zimmer GmbH recommends that the actuator and sensor voltage be supplied with power separately. The sensor supply must be switched on first.

As soon as the product is communicating with the PLC, the actuator power supply can be switched on. Depending on the application, simultaneous activation of both voltages is also possible.

INFORMATION



If the sensor supply is disconnected, the C/Q signal (IO-Link) must be disconnected as well.

11.6 Minimum travel path

The product requires a certain minimum travel path to generate the full gripping force when moving to the desired position.

Design size	Minimum travel path per gripper jaw [mm]
GEH6040IL-03-B	3
GEH6040IL-31-B	3
GEH6060IL-03-B	3
GEH6060IL-31-B	3
GEH6140IL-03-B	1
GEH6180IL-03-B	1
GED6040IL-03-A	4
GED6040IL-31-A	4
GED6140IL-03-A	2

11.7 Referencing by Homing

NOTICE



► Before each homing command, make sure that the product is able to move freely and easily and that it cannot be blocked by the gripper jaws or interfering edges.
When blocking, the reference position is set. A Homing command is not permitted in the gripped state.

There are various Homing commands available.

NOTICE



DeviceModes 16 and 17 are not valid for products with safety gripper jaws!

DeviceMode	Action
10	Outside homing – to the internal end stop of the product (see "DeviceMode 10" section)
14	Inside homing – to the internal end stop of the product (see "DeviceMode 14" section)
16	Special outside homing – to the external end stop (see "DeviceMode 16" section)
17	Special inside homing – to the external end stop (see "DeviceMode 17" section)

The product has reached its zero position if the gripper jaws are at the pictured position when referencing (Homing DeviceMode 10).

Depending on installation size, the gripper jaws move slightly beyond the edge of the gripper housing when moving to home position (Homing).

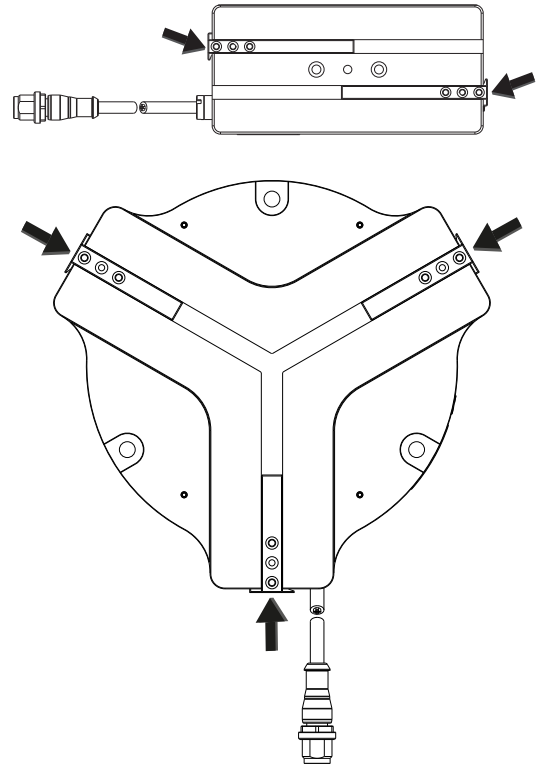

11.7.1 DeviceMode 10

- ▶ Assign "DeviceMode 10.
- ▶ Transmit this value to the product with a handshake.
 - The motor can be switched on or off.

WARNING



Risk of injury due to uncontrolled movements

Transmitting the value might cause the product to move.

- ▶ Always keep an adequate safety distance.
- ▶ Do not reach into the operational range of the product.

- ⇒ The gripper jaws move to the outside at low speed until they encounter the internal mechanical end stops.
- ⇒ If the gripper jaws encounter resistance, they stop at this spot.
 - ⇒ In the process, the ActualPosition is referenced to the value of 0.
- ⇒ The motor is switched on.

INFORMATION



For the products of the variants GEH6xxxIL-31-B and GED6xxxIL-31-A, the position can also take on a value higher than "0" after homing.

11.7.2 DeviceMode 14

- ▶ Assign DeviceMode 14.
- ▶ Transmit this value to the product with a handshake.
 - The motor can be switched on or off.

WARNING



Risk of injury due to uncontrolled movements

Transmitting the value might cause the product to move.

- ▶ Always keep an adequate safety distance.
- ▶ Do not reach into the operational range of the product.

- ⇒ The gripper jaws move to the inside at low speed until they encounter the internal mechanical end stops.
- ⇒ If the gripper jaws encounter resistance, they stop at this spot.
 - ⇒ In the process, the ActualPosition is referenced to the maximum jaw stroke of the product.
- ⇒ The motor is switched on.

INFORMATION



For the products of the variants GEH6xxxIL-31-B and GED6xxxIL-31-A, the ActualPosition can be less than the maximum position after homing.

11.7.3 DeviceMode 16

WARNING



Risk of injury due to increased force of the product during homing

The product force during the reference run is very high with DeviceMode 16.

- ▶ Make sure that an external end stop is installed in the machine or system into which the product is being installed.
- ⇒ If the internal end stop of the product is used, this will result in higher wear.

- ▶ Set the DriveVelocity to a low value before starting homing.
 - Recommendation: DriveVelocity **10**
 - ▶ Increase the value if a higher force is required for homing.
- ▶ Assign DeviceMode 3.
- ▶ Transmit this value to the product with ControlWord 1.
- ⇒ The motor is switched on.
- ▶ Transmit the following values.

Parameter	Value	Unit
DeviceMode	16	-
WorkpieceNo	0	-
PositionTolerance	50	0.01 mm
DriveVelocity	10	%
BasePosition	100	0.01 mm
WorkPosition	4000	0.01 mm

- ▶ Transmit the parameters to the product with a handshake.
 - ControlWord 1
 - BasePosition must not be smaller than 75.
- ⇒ The gripper jaws move to the outside until they encounter the internal mechanical end stops.
 - ⇒ After reaching the mechanical end stops, the product accepts the value of the BasePosition for the new ActualPosition.
 - ⇒ For example, this would be the new ActualPosition **100** (see table).
 - ⇒ After homing, the motor is switched off.
 - ▶ Switch the motor on using DeviceMode 3 and the handshake.
 - ▶ Change the movement profile.
 - ▶ Start the operation.
 - ⇒ The product responds with DiagnosisWord 0x0000.
 - ⇒ The product is ready.

WARNING



Risk of injury and material damage in case of non-compliance

Since the ActualPosition in this DeviceMode has an offset, the product does not know the position of the internal end stop.

- ⇒ This makes it possible to move against the internal end stop at high speed, which can result in jamming of and damage to the product.

INFORMATION



For the products of the variants GEH6xxxIL-31-B and GED6xxxIL-31-A, the ActualPosition can be greater than the specified BasePosition after homing.

11.7.4 DeviceMode 17

WARNING



Risk of injury due to increased force of the product during homing

The product force during the reference run is very high with DeviceMode 17.

- ▶ Make sure that an external end stop is installed in the machine or system into which the product is being installed.
- ⇒ If the internal end stop of the product is used, this will result in higher wear.

- ▶ Set the DriveVelocity to a low value before starting homing.
 - Recommendation: DriveVelocity **10**
 - ▶ Increase the value if a higher force is required for homing.
- ▶ Assign DeviceMode 3.
- ▶ Transmit this value to the product with ControlWord 1.
- ⇒ The motor is switched on.
- ▶ Transmit the following values.

Parameter	Value	Unit
DeviceMode	17	-
WorkpieceNo	0	-
PositionTolerance	50	0.01 mm
DriveVelocity	10	%
BasePosition	100	0.01 mm
WorkPosition	4000	0.01 mm

- ▶ Transmit the parameters to the product with a handshake.
 - ControlWord 1
 - WorkPosition must not be greater than the maximum position.
- ⇒ The gripper jaws move inward until they are stopped by an external end stop or the maximum jaw position.
 - ⇒ The product takes over the WorkPosition value as the new ActualPosition.
- ⇒ For example, this would be the new ActualPosition **4000** (see table).
- ⇒ After homing, the motor is switched off.
 - ▶ Switch the motor on using DeviceMode 3 and the handshake.
 - ▶ Change the movement profile.
 - ▶ Start the operation.
- ⇒ The product responds with DiagnosisWord 0x0000.
 - ⇒ The product is ready.

WARNING



Risk of injury and material damage in case of non-compliance

Since the ActualPosition in this DeviceMode has an offset, the product does not know the position of the internal end stop.

- ⇒ This makes it possible to move against the internal end stop at high speed, which can result in jamming of and damage to the product.

INFORMATION



For the products of the variants GEH6xxxIL-31-B and GED6xxxIL-31-A, the ActualPosition can be less than the specified WorkPosition after homing.

11.8 Movement profiles GEH6xxxIL-03-B/GED6xxxIL-03-A

Various operating modes are available for products with a self-locking mechanism.

DeviceMode	Description
5x	Positioning profiles
50	Positioning profile – standard
51	Positioning profile – high clock rate
6x	Force profiles – Outside gripping
60	Force profile – without holding pressure for energy-saving gripping.
61	Force profile – high clock rate for energy-saving gripping.
63	Force profile – with holding pressure for detecting part loss – standard
64	Force profile – with stronger holding pressure for detecting part loss.
65	Force profile – without holding pressure for flexible/elastic components.
7x	Force profiles – Inside gripping
70	Force profile – without holding pressure for energy-saving gripping.
71	Force profile – high clock rate for energy-saving gripping.
73	Force profile – with holding pressure for detecting part loss – standard
74	Force profile – with stronger holding pressure for detecting part loss.
75	Force profile – without holding pressure for flexible/elastic components.
8x	Pre-positioning – Force profiles – Outside gripping
80	Pre-positioning – Force profile – without holding pressure for energy-saving gripping.
81	Pre-positioning – Force profile – high clock rate for energy-saving gripping.
84	Pre-positioning – Force profile – with stronger holding pressure for detecting part loss.
85	Pre-positioning – Force profile – with holding pressure for detecting part loss.
9x	Pre-positioning – Force profiles – Inside gripping
90	Pre-positioning – Force profile – without holding pressure for energy-saving gripping.
91	Pre-positioning – Force profile – high clock rate for energy-saving gripping.
94	Pre-positioning – Force profile – with stronger holding pressure for detecting part loss.
95	Pre-positioning – Force profile – with holding pressure for detecting part loss.

11.8.1 Positioning profiles

Modes 50 and 51 can be used for positioning the product or for form-fit gripping.

The movement speed is configured using the DriveVelocity parameter.

The TeachPosition and ShiftPosition parameters do not have any significance in this mode because the BasePosition or WorkPosition is always approached precisely.

If the product encounters an obstacle in this mode, the movement stops.

The product can be moved from the obstacle back to the starting position if the command is switched in the ControlWord.

No defined gripping forces can be generated in this mode. As a result, friction-locked gripping is not permitted in this mode.

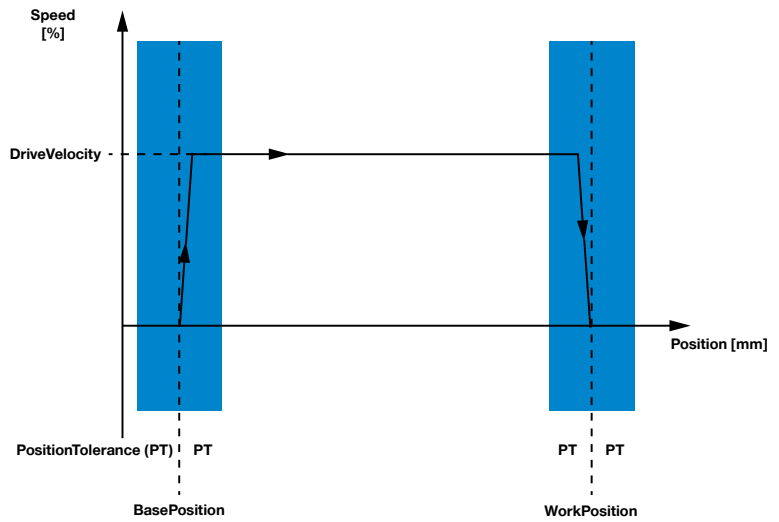

DeviceMode	Action	ControlWord
50	Positioning to BasePosition or WorkPosition	0x0100/0x0200
51	Positioning without an unlocking operation to BasePosition or WorkPosition	0x0100/0x0200

Positioning profile 50 – standard

The move commands in the ControlWord trigger a movement in the corresponding direction at DriveVelocity.

Positioning profile 51 – high clock rate

Behaves like mode 50, but when the gripping movement starts, the unlocking operation is omitted. This enables a shorter response time.

- ▶ Ensure that no gripping force is acting on the gripper jaws.
- ⇒ The movement may stop as a result.

11.8.2 Force profiles

Mode Groups 60 and 70 can be used for form-fit gripping.

The gripping force is built up by the movement speed of the product and the motor current. The product calculates the required GripVelocity automatically from the GripForce parameter.

When gripping a workpiece, a mechanical locking system is triggered that makes it possible to hold the workpiece de-energized. To release the locking system, an unlocking operation must be carried out.

To unlock, the product must be moved toward the standby position at DriveVelocity. The product then switches into positioning mode.

The figure shows outside gripping using Mode Group 60 as an example. For Mode Group 70, the BasePosition and the WorkPosition are exchanged.

The figure shows inside gripping using Mode Group 60 as an example. For Mode Group 70, the BasePosition and the WorkPosition are exchanged.

Gripping in the direction of WorkPosition

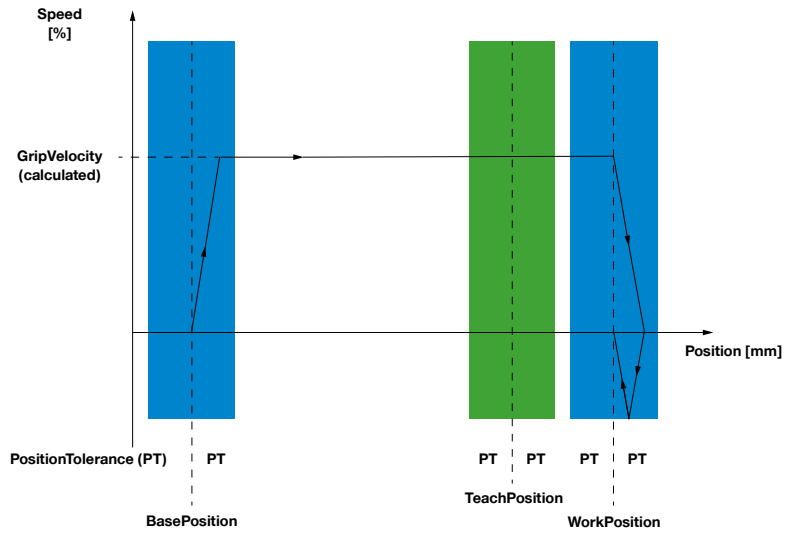

Opening

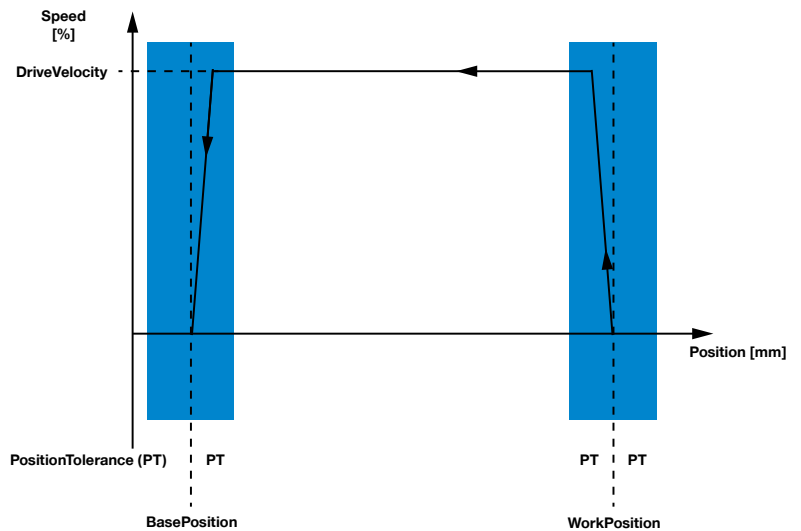

Parameter	Description
BasePosition	Open position
WorkPosition	Closed position
GripForce	Desired gripping force
TeachPosition	Expected position of the workpiece
PositionTolerance	Permitted tolerance for the workpiece
DriveVelocity	Opening speed
ShiftPosition	Not used

The movement profile determines the direction in which the workpiece is gripped:

- Outside gripping: Movement profile group 60
- Inside gripping: Movement profile group 70

11.8.2.1 Force profiles group 60 – Outside gripping

In Mode Group 60, the product moves in the ForceProfile from the BasePosition toward the WorkPosition onto the workpiece with ControlWord 0x0200.

The workpiece is gripped and the set gripping force is built up. The self-locking mechanism is activated automatically. For releasing, an unlocking operation must be carried out.

If no workpiece is gripped during the gripping process, the product moves on to the WorkPosition and is braked. The product moves behind the configured position before it turns around and comes to a stop at the WorkPosition. This enables secure gripping of workpieces up to the WorkPosition.

The ControlWord 0x0100 is used to open the product. The product is moved automatically to the BasePosition in the PositionProfile.

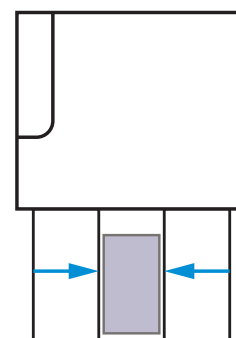

DeviceMode	Action	ControlWord
6x	Move toward the BasePosition to open the product.	0x0100
60	Move toward the WorkPosition until this position or the workpiece is reached.	0x0200
61	Move toward the WorkPosition until this position or the workpiece is reached. Do not carry out an unlocking process.	0x0200
63	Move toward the WorkPosition until this position or the workpiece is reached. Carry out test for part loss.	0x0200
64	Move toward the WorkPosition until this position or the workpiece is reached. Carry out test for part loss with stronger holding pressure force.	0x0200
65	Move toward the WorkPosition until this position or the workpiece is reached. Move at a reduced speed.	0x0200

Force profile 60 – without holding pressure for energy-saving gripping

Before the movement starts, an unlocking operation is run for releasing. Then, the product starts moving toward the workpiece. If the product encounters the workpiece while moving, an increase in current is detected and the gripping force is built up. The self-locking mechanism is triggered automatically and the motor is practically de-energized.

- ▶ If the workpiece disengages from the gripper, the gripper jaws do not follow along and no part loss can be detected.
- ⇒ Recommended energy saving mode

Force profile 61 - high cycle rate for energy-saving gripping

Behaves like mode 60, but when the gripping movement starts, the unlocking operation is omitted and the movement is started immediately. This enables a shorter response time during the drive to the WorkPosition.

- ▶ Ensure that in the BasePosition, no external forces act on the gripper jaws.

Force profile 63 - with holding pressure for detection of part loss

Behaves like force profile 60, with the addition that in this mode, the motor is energized continuously after gripping the workpiece. After the gripping process, the TeachPosition bit is TRUE. In case a part is lost, this causes the machine to move on to the WorkPosition. The part loss can be detected by sensing the WorkPosition.

- ⇒ Recommended standard operating mode

Force profile 64 - with stronger holding pressure for detection of part loss

Behaves like force profile 63, but the motor is energized with more current. This increases the holding pressure force, but the heating of the gripper and the energy consumption increase.

Force profile 65 - without holding pressure for flexible/elastic components

Behaves like force profile 60, but the product has a lower movement speed because the majority of the gripping force is created directly by the motor current. It will no longer be possible to generate the full nominal force in the movement because of the lower kinetic energy. The gripping force generated depends on the elasticity of the workpiece.

- ⇒ Recommended mode for flexible/elastic workpieces

11.8.2.2 Force profiles group 70 – Inside gripping

In Mode Group 70, the product in the ForceProfile moves from the BasePosition toward the WorkPosition onto the workpiece with ControlWord 0x0100.

The workpiece is gripped and the set gripping force is built up. The self-locking mechanism is activated automatically. For releasing, an unlocking operation must be carried out.

If no workpiece is gripped during the gripping process, the product moves on to the WorkPosition and is then braked. The product moves behind the configured position before it turns around and comes to a stop at the BasePosition. This enables secure gripping of workpieces up to the BasePosition.

The ControlWord 0x0200 is used to open the product. The product is moved automatically to the WorkPosition in the PositionProfile.

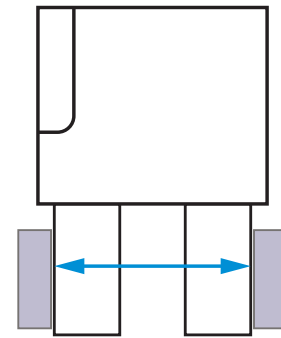

DeviceMode	Action	ControlWord
7x	Move toward the WorkPosition for opening the product.	0x0200
70	Move toward the BasePosition until this position or the workpiece is reached.	0x0100
71	Move toward the BasePosition until this position or the workpiece is reached. Do not carry out an unlocking process.	0x0100
73	Move toward the BasePosition until this position or the workpiece is reached. Carry out test for part loss.	0x0100
74	Move toward the BasePosition until this position or the workpiece is reached. Carry out test for part loss with stronger holding pressure force.	0x0100
75	Move toward the BasePosition until this position or the workpiece is reached. Move at a reduced speed.	0x0100

Force profile 70 - without holding pressure for energy-saving gripping

When the movement starts, an unlocking operation is run for releasing. Then, the product starts moving toward the workpiece. If the product encounters the workpiece while moving, an increase in current is detected and the gripping force is built up. The self-locking mechanism is triggered automatically and the motor is practically de-energized.

- ▶ If the workpiece disengages from the gripper, the gripper jaws do not follow along and no part loss can be detected.
- ⇒ Recommended energy saving mode

Force profile 71 - high cycle rate for energy-saving gripping

Behaves like mode 70, but when the gripping movement starts, the unlocking operation is omitted and the movement is started immediately. This enables a shorter response time during the drive to the BasePosition.

- ▶ Ensure that in the WorkPosition, no external forces act on the gripper jaws.

Force profile 73 - with holding pressure for detection of part loss

Behaves like force profile 70, with the addition that in this mode, the motor is energized continuously after gripping the workpiece. After the gripping process, the TeachPosition bit is TRUE. In case a part is lost, this causes the machine to move on to the BasePosition. The part loss can be detected by sensing the BasePosition.

- ⇒ Recommended standard operating mode

Force profile 74 - with stronger holding pressure for detection of part loss

Behaves like force profile 73, but the motor is energized with more current. This increases the holding pressure force, but the heating of the gripper and the energy consumption increase.

Force profile 75 - without holding pressure for flexible/elastic components

Behaves like force profile 70, but the product has a lower movement speed because the majority of the gripping force is created directly by the motor current. It will no longer be possible to generate the full nominal force in the movement because of the lower kinetic energy. The gripping force generated depends on the elasticity of the workpiece.

- ⇒ Recommended mode for flexible/elastic workpieces

11.8.2.3 Pre-positioning force profiles

For Mode Groups 80 and 90, pre-positioning is used. Therefore, these groups are particularly suitable for time-optimized gripping with long strokes followed by force-fit gripping.

The gripping force is built up by the movement speed of the product and the motor current. The product calculates the required GripVelocity automatically from the GripForce parameter.

When gripping a workpiece, a mechanical locking system is triggered that makes it possible to hold the workpiece de-energized. To release the locking system, an unlocking operation must be carried out.

To unlock, the product must be moved toward the standby position at DriveVelocity. The product then switches into positioning mode.

The figure shows outside gripping using Mode Group 80 as an example. For Mode Group 90, the BasePosition and the WorkPosition are exchanged.

The figure shows outside gripping using Mode Group 80 as an example. For Mode Group 90, the BasePosition and the WorkPosition are exchanged.

Gripping in the direction of WorkPosition

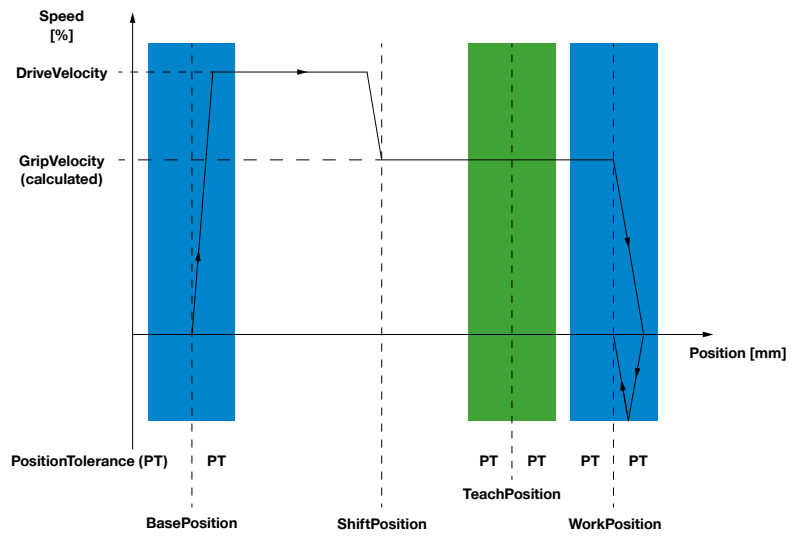

Opening

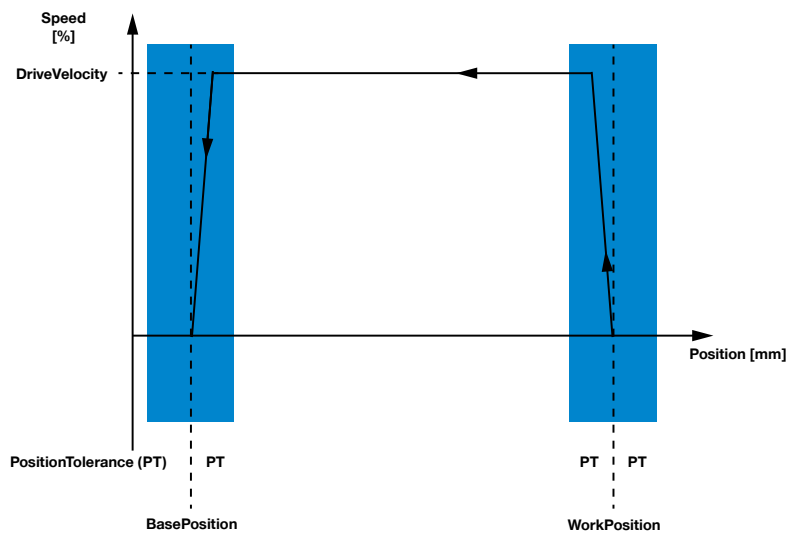

Parameter	Description
BasePosition	Open position
WorkPosition	Closed position – behind the workpiece
GripForce	Desired gripping force
TeachPosition	Expected position of the workpiece
PositionTolerance	Permitted tolerance for the workpiece

Since gripping should occur in one direction only, the positioning mode is used automatically in the opposite direction. The movement profile determines the direction in which the workpiece is gripped:

- Outside gripping: Movement profile group 80
- Inside gripping: Movement profile group 90

11.8.2.4 Pre-positioning force profiles group 80 – Outside gripping

In Mode Group 80, the product moves with ControlWord 0x0200 in the PositionProfile toward the ShiftPosition. Then, the product moves in ForceProfile and Gripforce moves from the ShiftPosition toward the WorkPosition onto the workpiece.

The workpiece is gripped and the set gripping force is built up. The self-locking mechanism is activated automatically. For releasing, an unlocking operation must be carried out.

If no workpiece is gripped during the gripping process, the product moves on to the WorkPosition and is braked. The product moves behind the configured position before it turns around and comes to a stop at the WorkPosition. This enables secure gripping of workpieces up to the WorkPosition.

The ControlWord 0x0100 is used to open the product. The product is moved automatically to the BasePosition in the PositionProfile.

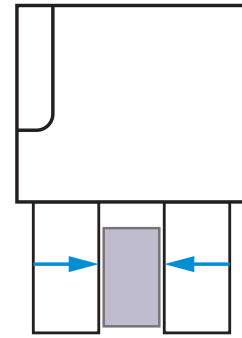

DeviceMode	Action	ControlWord
8x	Move toward the BasePosition to open the product.	0x0100
80	Move in the direction of the WorkPosition at DriveVelocity until the ShiftPosition is reached. Switch to GripForce until the WorkPosition or the workpiece is reached.	0x0200
81	Move in the direction of the WorkPosition at DriveVelocity until the ShiftPosition is reached. Switch to GripForce until the WorkPosition or the workpiece is reached. Do not carry out an unlocking process.	0x0200
84	Move toward the WorkPosition until this position or the workpiece is reached. Carry out test for part loss with stronger holding pressure force.	0x0200
85	Move toward the WorkPosition until this position or the workpiece is reached. Carry out test for part loss.	0x0200

Pre-positioning force profile 80 – without holding pressure for energy-saving gripping

Before the movement starts, an unlocking operation is run for releasing. The movement begins with the positioning to the shift position. The gripper moves at the speed set in the Drive Velocity parameter. Then, the product starts moving toward the workpiece with GripForce. If the product encounters the workpiece while moving, an increase in current is detected and the gripping force is built up. The self-locking mechanism is triggered automatically and the motor is practically de-energized. This enables energy-saving gripping.

If the workpiece disengages from the gripper, the gripper jaws do not follow along and no part loss can be detected.

Pre-positioning force profile 81 - high cycle rate for energy-saving gripping

Behaves like mode 80, but when the gripping movement starts, the unlocking operation is omitted and the movement is started immediately. This enables a shorter response time during the drive to the WorkPosition.

- Ensure that no forces act on the gripper jaws in the BasePosition.

Pre-positioning - Force profile 84 - with stronger holding pressure for detection of part loss

Behaves like force profile 85, but the motor is energized with more current. This increases the holding pressure force, but the heating of the gripper and the energy consumption increase.

Pre-positioning force profile 85 - with holding pressure for detection of part loss

Behaves like force profile 80, with the addition that in this mode, the motor is energized continuously after gripping the workpiece. If the gripping process was successful, the bit in the TeachPosition becomes TRUE. In case a part is lost, the product keeps moving to the WorkPosition. The part loss can be detected by sensing the WorkPosition.

11.8.2.5 Pre-positioning force profiles group 90 – Inside gripping

In Mode Group 90, the product moves with ControlWord 0x0100 in the PositionProfile toward the ShiftPosition. Then, the product moves in ForceProfile and Gripforce moves from the ShiftPosition toward the WorkPosition onto the workpiece.

The workpiece is gripped and the set gripping force is built up. The self-locking mechanism is activated automatically. For releasing, an unlocking operation must be carried out.

If no workpiece is gripped during the gripping process, the product moves on to the WorkPosition and is then braked. The product moves behind the configured position before it turns around and comes to a stop at the BasePosition. This enables secure gripping of workpieces up to the BasePosition.

The ControlWord 0x0200 is used to open the product. The product is moved automatically to the WorkPosition in the PositionProfile.

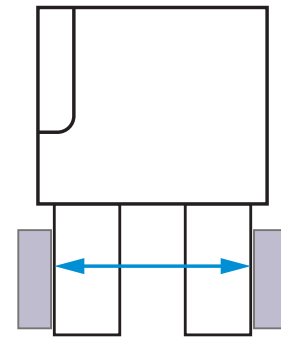

DeviceMode	Action	ControlWord
9x	Move toward the WorkPosition for opening the product.	0x0200
90	Move in the direction of the BasePosition at DriveVelocity until the ShiftPosition is reached. Switch to GripForce until the BasePosition or the workpiece is reached.	0x0100
91	Move in the direction of the BasePosition at DriveVelocity until the ShiftPosition is reached. Switch to GripForce until the BasePosition or the workpiece is reached. Do not carry out an unlocking process.	0x0100
94	Move toward the BasePosition until this position or the workpiece is reached. Carry out test for part loss with stronger holding pressure force.	0x0100
95	Move toward the BasePosition until this position or the workpiece is reached. Carry out test for part loss.	0x0100

Pre-positioning force profile 90 – without holding pressure for energy-saving gripping

Before the movement starts, an unlocking operation is run for releasing. The movement begins with the positioning to the shift position. The gripper moves at the speed set in the Drive Velocity parameter. Then, the product starts moving toward the workpiece with GripForce. If the product encounters the workpiece while moving, an increase in current is detected and the gripping force is built up. The self-locking mechanism is triggered automatically and the motor is practically de-energized. This enables energy-saving gripping.

- ▶ If the workpiece disengages from the gripper, the gripper jaws do not follow along and no part loss can be detected.

Pre-positioning force profile 91 - high cycle rate for energy-saving gripping

Behaves like mode 90, but when the gripping movement starts, the unlocking operation is omitted and the movement is started immediately. This enables a shorter response time during the drive to the WorkPosition.

- ▶ Ensure that in the WorkPosition, no forces act on the gripper jaws.

Pre-positioning - Force profile 94 - with stronger holding pressure for detection of part loss

Behaves like force profile 93, but the motor is energized with more current. This increases the holding pressure force, but the heating of the gripper and the energy consumption increase.

Pre-positioning force profile 95 - with holding pressure for detection of part loss

Behaves like force profile 90, with the addition that in this mode, the motor is energized continuously after gripping the workpiece. After the gripping process, the bit in the TeachPosition is TRUE. In case a part is lost, the product moves to the BasePosition. The part loss can be detected by sensing the BasePosition.

11.9 Movement profiles GEH6xxxIL-31-B/GED6xxxIL-31-A

Various operating modes are available for products without a self-locking mechanism.

11.9.1 DeviceModes

DeviceMode	Description
5x	Positioning profiles
50	Positioning profile – standard
51	Positioning profile – high clock rate
6x	Force profiles – Outside gripping
62	Force profile – standard without self-locking mechanism
7x	Force profiles – Inside gripping
72	Force profile – standard without self-locking mechanism
8x	Pre-positioning – Force profiles – Outside gripping
82	Pre-positioning – Force profile without self-locking mechanism
9x	Pre-positioning – Force profiles – Inside gripping
92	Pre-positioning – Force profile without self-locking mechanism

INFORMATION



Products without a self-locking mechanism exert lower gripping forces due to the increased movement speed. There is no gripping force retention from a self-locking mechanism. The motor is energized continuously during the gripping process. If the workpiece gets lost, the gripping movement is continued to the target position.

11.9.2 Positioning profiles

Modes 50 and 51 can be used for positioning the product or for form-fit gripping.

The movement speed is configured using the DriveVelocity parameter.

The TeachPosition and ShiftPosition parameters do not have any significance in this mode because the BasePosition or WorkPosition is always approached precisely.

If the product encounters an obstacle in this mode, the movement stops.

The product can be moved from the obstacle back to the starting position if the command is switched in the ControlWord.

No defined gripping forces can be generated in this mode. As a result, friction-locked gripping is not permitted in this mode.

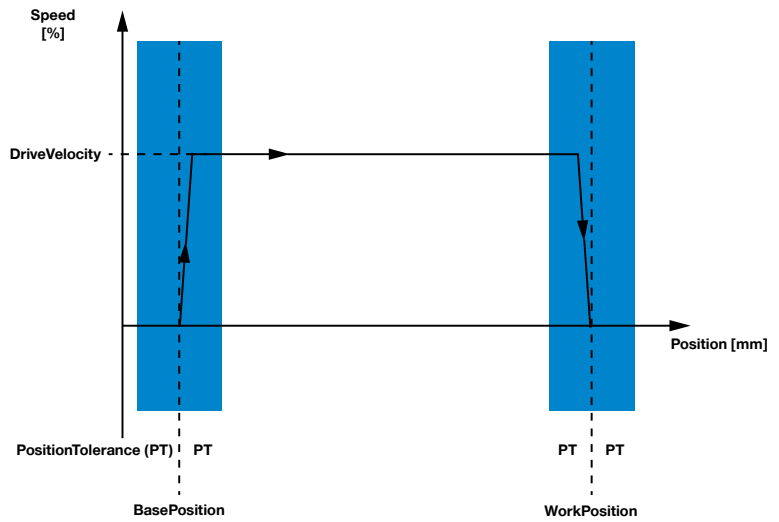

DeviceMode	Action	ControlWord
50	Positioning to BasePosition or WorkPosition	0x0100/0x0200
51	Positioning without an unlocking operation to BasePosition or WorkPosition	0x0100/0x0200

Positioning profile 50 – standard

The move commands in the ControlWord trigger a movement in the corresponding direction at DriveVelocity.

Positioning profile 51 – high clock rate

Behaves like mode 50, but when the gripping movement starts, the unlocking operation is omitted. This enables a shorter response time.

- ▶ Ensure that no gripping force is acting on the gripper jaws.
- ⇒ The movement may stop as a result.

11.9.3 Force profiles

Mode Groups 60 and 70 can be used for form-fit gripping.

The gripping force is built up by the movement speed of the product and the motor current. The product calculates the required GripVelocity automatically from the GripForce parameter.

For opening, the product moves toward the standby position at DriveVelocity. The product switches into positioning mode automatically.

The figure shows outside gripping using Mode Group 60 as an example. For Mode Group 70, the BasePosition and the WorkPosition are exchanged.

Gripping in the direction of WorkPosition

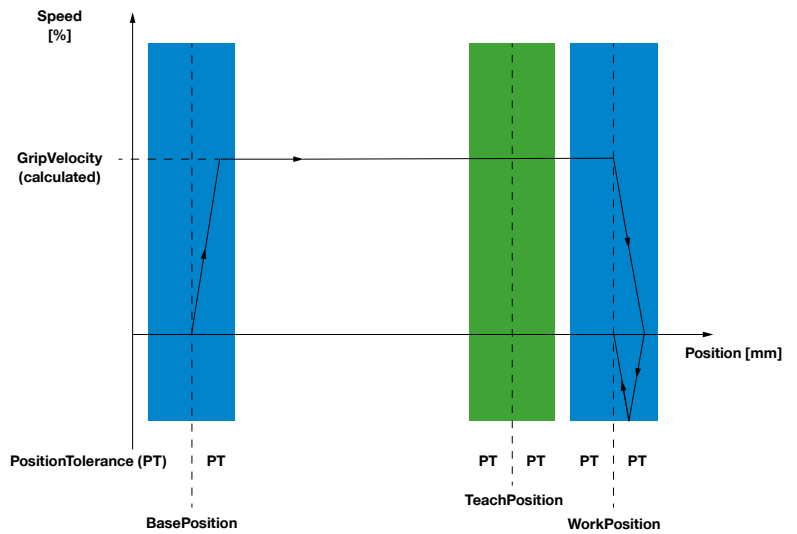

Opening

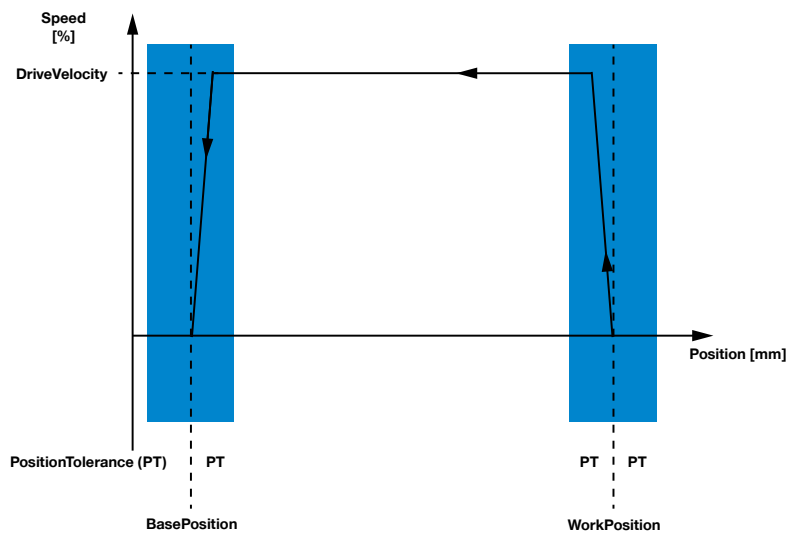

Parameter	Description
BasePosition	Open position
WorkPosition	Closed position
GripForce	Desired gripping force
TeachPosition	Expected position of the workpiece
PositionTolerance	Permitted tolerance for the workpiece
DriveVelocity	Opening speed
ShiftPosition	Not used

Since gripping should occur in one direction only, the positioning mode is used automatically in the opposite direction. When opening, the product switches into positioning mode automatically.

The movement profile determines the direction in which the workpiece is gripped:

- Outside gripping: Movement profile group 60
- Inside gripping: Movement profile group 70

11.9.3.1 Force profiles group 60 – Outside gripping

In Mode Group 60, the product moves in the ForceProfile from the BasePosition toward the WorkPosition onto the workpiece with ControlWord 0x0200.

The workpiece is gripped; the configured gripping force is built up and maintained by the motor current.

If no workpiece is gripped during the gripping process, the product moves on to the WorkPosition and is braked. The product moves behind the configured position before it turns around and comes to a stop at the WorkPosition. This enables secure gripping of workpieces up to the WorkPosition.

The ControlWord 0x0100 is used to open the product. The product is moved automatically to the BasePosition in the PositionProfile.

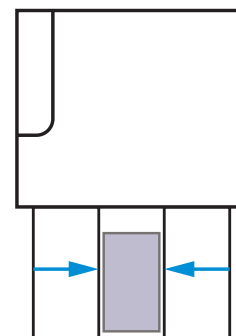

Mode Group 60 – typically used for outside gripping

DeviceMode	Action	ControlWord
62	Move toward the BasePosition to open the product.	0x0100
62	Move toward the WorkPosition until this position or the workpiece is reached. Do not carry out an unlocking process.	0x0200

Force profile 62 - Standard without self-locking mechanism

The product moves toward the workpiece. When the product grips the workpiece, the configured gripping force is built up and maintained by the motor current.

11.9.3.2 Force profiles group 70 – Inside gripping

In Mode Group 70, the product in the ForceProfile moves from the BasePosition toward the WorkPosition onto the workpiece with ControlWord 0x0100.

The workpiece is gripped; the configured gripping force is built up and maintained by the motor current.

If no workpiece is gripped during the gripping process, the product moves on to the WorkPosition and is then braked. The product moves behind the configured position before it turns around and comes to a stop at the BasePosition. This enables secure gripping of workpieces up to the BasePosition.

The ControlWord 0x0200 is used to open the product. The product is moved automatically to the WorkPosition in the PositionProfile.

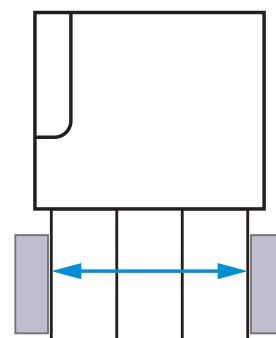

Mode Group 70 – typically used for inside gripping

DeviceMode	Action	ControlWord
72	Move toward the WorkPosition for opening the product.	0x0200
72	Move toward the BasePosition until this position or the workpiece is reached.	0x0100

Force profile 72 - Standard without self-locking mechanism

The product moves toward the workpiece. When the product grips the workpiece, the configured gripping force is built up and maintained by the motor current.

11.9.3.3 Pre-positioning force profiles

For Mode Groups 80 and 90, pre-positioning is used. Therefore, these groups are particularly suitable for time-optimized gripping with long strokes followed by force-fit gripping.

The gripping force is built up by the movement speed of the product and the motor current. The product calculates the required GripVelocity automatically from the GripForce parameter.

For opening, the product moves toward the standby position at DriveVelocity. The product switches into positioning mode automatically.

The figure shows outside gripping using Mode Group 80 as an example. For Mode Group 90, the BasePosition and the WorkPosition are exchanged.

Gripping in the direction of WorkPosition

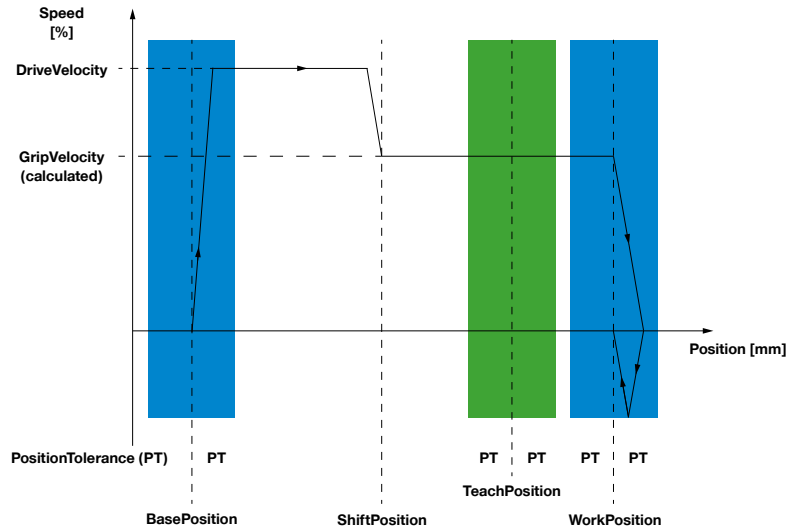

Opening

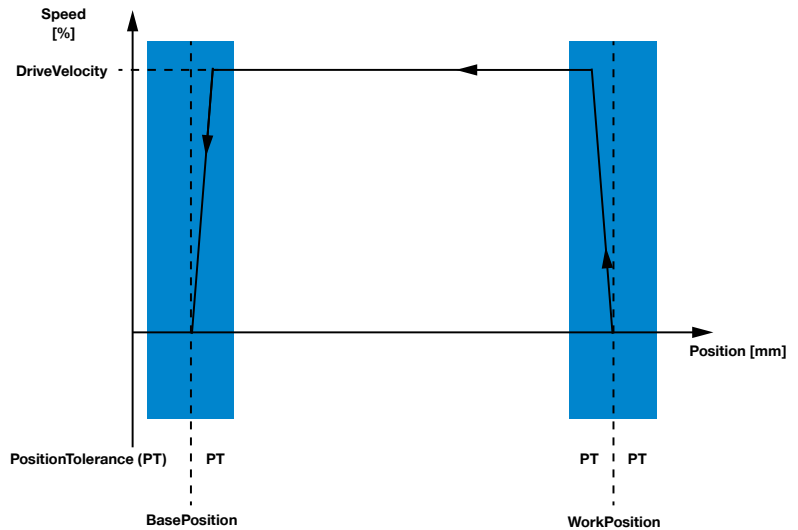

Parameter	Description
BasePosition	Open position
ShiftPosition	Switching from positioning to gripping
WorkPosition	Closed position
GripForce	Desired gripping force
TeachPosition	Expected position of the workpiece
PositionTolerance	Permitted tolerance for the workpiece
DriveVelocity	Opening speed

Since gripping should occur in one direction only, the positioning mode is used automatically in the opposite direction. The movement profile determines the direction in which the workpiece is gripped:

- Outside gripping: Movement profile group 80
- Inside gripping: Movement profile group 90

11.9.3.4 Pre-positioning force profiles group 80 – Outside gripping

In Mode Group 80, the product moves with ControlWord 0x0200 in the PositionProfile toward the ShiftPosition. Then, the product moves in ForceProfile and Gripforce moves from the ShiftPosition toward the WorkPosition onto the workpiece.

The workpiece is gripped; the configured gripping force is built up and maintained by the motor current.

If no workpiece is gripped during the gripping process, the product moves on to the WorkPosition and is braked. The product moves behind the configured position before it turns around and comes to a stop at the WorkPosition. This enables secure gripping of workpieces up to the WorkPosition.

The ControlWord 0x0100 is used to open the product. The product is moved automatically to the BasePosition in the PositionProfile.

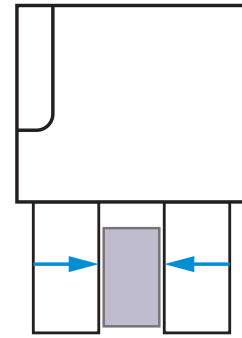

Mode Group 82 – typically used for outside gripping

DeviceMode	Action	ControlWord
82	Move toward the BasePosition to open the product.	0x0100
82	Move to ShiftPosition at DriveVelocity, then switch to GripForce until the WorkPosition or the workpiece is reached.	0x0200

Pre-positioning force profile group 82 – Standard

The movement starts from the BasePosition and begins with the positioning to the shift position. The gripper moves at the speed set in the Drive Velocity parameter. Then, the product starts moving toward the workpiece with GripForce. If the product encounters the workpiece while moving, an increase in current is detected and the gripping force is built up. The gripping force is maintained by the motor current.

11.9.3.5 Pre-positioning force profiles group 90 – Inside gripping

In Mode Group 90, the product moves with ControlWord 0x0100 in the PositionProfile toward the ShiftPosition. Then, the product moves in ForceProfile and Gripforce moves from the ShiftPosition toward the WorkPosition onto the workpiece.

The workpiece is gripped; the configured gripping force is built up and maintained by the motor current.

If no workpiece is gripped during the gripping process, the product moves on to the WorkPosition and is then braked. The product moves behind the configured position before it turns around and comes to a stop at the BasePosition. This enables secure gripping of workpieces up to the BasePosition.

The ControlWord 0x0200 is used to open the product. The product is moved automatically to the WorkPosition in the PositionProfile.

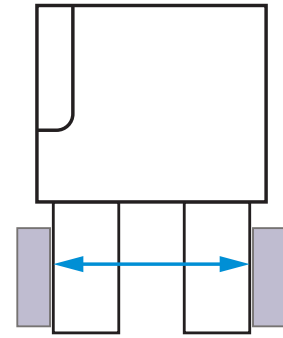

Mode Group 92 – typically used for inside gripping

DeviceMode	Action	ControlWord
92	Move toward the WorkPosition for opening the product.	0x0200
92	Move to ShiftPosition at DriveVelocity, then switch to GripForce until the BasePosition or the workpiece is reached.	0x0100

Pre-positioning force profile group 90 – Standard

The movement starts from the WorkPosition and begins with the positioning to the shift position. The gripper moves at the speed set in the Drive Velocity parameter. Then, the product starts moving toward the workpiece with GripForce. If the product encounters the workpiece while moving, an increase in current is detected and the gripping force is built up. The set gripping force is maintained by the motor current.

11.10 Interrupting the voltage supply

NOTICE



Switching off the power supply can cause smaller movements of the product. These can add up over time to more severe positioning errors.

During an interruption of the voltage supply (e.g. when using a tool changer), make absolutely sure that the product stores the last position in the controller.

- ▶ Carry out a handshake before switching off the power supply.
- ⇒ This ensures that no change of position occurs during a restart.

The following example code shows the sequence in case the power supply is interrupted.

```
// Interruption of the power supply
// Switching off the motor
CASE iStep OF
0:
    DeviceMode      := 5;      // Motor off
    ControlWord     := 1;      // Start handshake (DataTransfer bit =TRUE in the ControlWord)
    iStep           := 10;     // Jump to the next step

10:
    IF StatusBit.12 AND NOT StatusBit.1 THEN // Queries the bit DataTransferOK=TRUE from StatusWord,
                                                // Response of the product to transferred data
        ControlWord     := 0;      // Reset the ControlWord
        iStep           := 20;     // Jump to the next step
    END_IF;

20:
    IF NOT StatusWord.12 THEN
        // Voltage supply can be interrupted
    END_IF
```

11.11 Easy Startup

Describes the process from switching on the product to the initial movement.

- ▶ Connect the product according to its assignment diagram.
- ⇒ The product reports the process parameters StatusWord, Diagnosis and ActualPosition immediately after the internal controller is booted up.
- ⇒ As soon as the PLCActive bit is registered in the StatusWord, the communication process can start.
- ▶ Transmit the process parameters to move the product.
 - DeviceMode
 - WorkpieceNo
 - PositionTolerance
 - GripForce
 - DriveVelocity
 - BasePosition
 - ShiftPosition
 - TeachPosition
 - WorkPosition
- ▶ Transmit the parameters to the product with a handshake.

INFORMATION

- ▶ For information and an example code for the handshake, refer to the "Quickstart Basic Parameters" and "Recipe Examples" sections.

11.12 Starting the data transfer

- ▶ Start the data transmission with the ControlWord = 1 (decimal).
- ⇒ As soon as the process parameter has been transmitted to the product, the product will report this back in the StatusWord with the DataTransferOK bit.
- ⇒ The product is ready to operate.

INFORMATION

- ▶ For information about data transfers, refer to the "StatusWord" section.

11.13 Quickstart Basic Parameters

INFORMATION



The following example code applies to the products GEH6xxxIL-03-B and GED6xxxIL-03-A with a self-locking mechanism.

For products without a self-locking mechanism, Mode Group 82 must be used for operation.

In the following example, you see the first initialization of the product, the activation of the motor and the transmission of the process parameters.

```
// Initialization of the product
// Motor switch-on
// Initial move command
// = EasyStartUp Example
CASE iStep OF
0:
    IF StatusBit.6 and Diag != 0x100 THEN // Query for PLCActive bit in the StatusWord
        ControlWord := 1; // Data transfer to the product
        DeviceMode := 3; // Command to switch on the motor
        WorkpieceNo := 0; // 0 = current process parameters are being used
        PositionTolerance := 50;
        GripForce := 50;
        DriveVelocity := 50;
        BasePosition := 100;
        ShiftPosition := 2000;
        TeachPosition := 3800;
        WorkPosition := 4000;
        iStep := 10; // Jump to the next step
    END_IF
10:
    IF StatusBit.12 AND StatusBit.1 THEN // Query for DataTransferOK bit AND MotorON in the StatusWord
        ControlWord := 0; // Reset of the initialization
        iStep := 20; // Jump to the next step
    END_IF
20:
    IF NOT StatusWord.12 THEN // Query for completion of the data transfer,
        // DataTransferOK = FALSE
        DeviceMode := 85; // Loading a DeviceMode
        ControlWord := 1; // Begins with the handshake
        iStep := 30; // Jump to the next step
    END_IF
30:
    IF StatusWord.12 THEN // Queries the bit DataTransferOK=TRUE from StatusWord,
        // Response of the product to transferred data
        ControlWord := 0; // Reset of the ControlWord
        iStep := 40; // Jump to the next step
    END_IF
40:
    IF NOT StatusWord.12 THEN // Query for completion of the data transfer,
        // DataTransferOK = FALSE
        ControlWord := 512; // Handshake is completed,
        // Product moves to WorkPosition (0x0200 or 512(decimal) = MoveToWork)
        iStep := 50; // Jump to the next step
    END_IF
50:
    IF NOT StatusWord.10 THEN // Query for reaching the WorkPosition
        ControlWord := 256; // Set move command toward BasePosition
        iStep := 60;
    END_IF;
END_CASE
```

11.14 Starting the gripping movement

- ▶ Send ControlWord 0x0200 so that the product moves towards the WorkPosition.
- ⇒ The gripper jaws move towards the inside.
- ▶ Send ControlWord 0x0100 so that the product moves towards the BasePosition.
- ⇒ The gripper jaws move towards the outside.
 - The motion task must be pending for as long as it takes until the desired position is reached.
 - The current motion task is canceled as a result of a new handshake.
- ⇒ When the product reaches the corresponding position, this is displayed in the StatusWord as follows:
 - The product is at the BasePosition: StatusWord bit 8 = TRUE
 - The product is at the TeachPosition: StatusWord bit 9 = TRUE
 - The product is at the WorkPosition: StatusWord bit 10 = TRUE
 - The product is not at any of the listed positions: StatusWord bit 11 = TRUE

11.15 Repeated movements in the same direction

The StatusWord includes two static flag bits, each of which is set in alternation when the product moves in one direction. This prevents uncontrolled movements of the product in case of faulty data transmission.

Depending on the location of the positions, it is possible that the product may move multiple times in the same direction. For this purpose, the direction flags must be reset.

- ▶ Send the ControlWord = 0x0004 to delete the direction flags.
- ⇒ The direction flags are reset when the product answers with status bit 13 AND 14 = FALSE.

Program example for repeated movements in the same direction:

```
// Multiple movement in one direction in Structured Text (ST)
// In this example, the motor is switched on,
// The movement profile
// Transfer gripping forces and speeds
// The product is at BasePosition = 1000.
CASE iStep OF
10:
    BasePosition      := 100;    // Assignment of a new BasePosition
    ControlWord       := 1;      // Start handshake (DataTransfer bit =TRUE in the ControlWord)
    iStep              := 20;    // Jump to the next step
END_IF;
20:
    IF StatusWord.12 THEN        // Queries the bit DataTransferOK=TRUE from StatusWord,
                                // Response of the product to transferred data
        ControlWord           := 0;    // Reset the ControlWord
        iStep                  := 30;    // Jump to the next step
    END_IF;
30:
    IF NOT StatusWord.12 THEN   // Query for completion of the data transfer,
                                // DataTransferOK = FALSE
        ControlWord           := 4;    // Reset direction flag
                                // (DataTransfer bit =TRUE in the ControlWord)
        iStep                  := 40;
    END_IF
40:
    IF NOT StatusWord.13 AND NOT // Query whether both direction flags
    StatusWord.14 THEN          // (Bit ControlWord 0x0100 AND
                                // ControlWord 0x0200 = FALSE in ControlWord)
        ControlWord           := 256; // Moves back toward BasePosition
        iStep                  := 50;
    END_IF;
END_CASE
```

11.16 Recipe examples

11.16.1 Save recipe

INFORMATION



The following example code applies to the products GEH6xxxIL-03-B and GED6xxxIL-03-A with a self-locking mechanism.

For products without a self-locking mechanism, Mode Group 82 must be used for operation.

The following example code shows how process parameters can be stored in the internal workpiece recipe.

CASE iStep OF

10:

```
IF StatusBit.6 and Diag != 0x100 THEN
    DeviceMode      := 85;    // Assignment of desired process parameters
    WorkpieceNo     := 3;    // Recipe is to be stored as the third workpiece recipe
    PositionTolerance := 50;
    GripForce       := 50;
    DriveVelocity   := 50;
    BasePosition    := 100;
    ShiftPosition   := 2000;
    TeachPosition   := 3800;
    WorkPosition    := 4000;
    iStep           := 20;    // Jump to the next step
```

END_IF;

20:

```
ControlWord := 1;    // Begins with the handshake
iStep       := 30;    // Jump to the next step
```

30:

```
IF StatusWord.12 THEN // Queries the bit DataTransferOK=TRUE from StatusWord,
                      // Response of the product to transferred data
    ControlWord := 0; // Reset the ControlWord
    iStep       := 40; // Jump to the next step
```

END_IF;

40:

```
IF NOT StatusWord.12 THEN // Query for completion of the data transfer,
                          // DataTransferOK = FALSE
    ControlWord := 2; // Handshake is completed,
                      // storage starts here via the WritePDU bit in the ControlWord
    iStep       := 50; // Jump to the next step
```

END_IF;

50:

```
IF StatusWord.12 THEN // Queries the DataTransferOK = TRUE bit from StatusWord
    ControlWord := 0; // Reset the ControlWord
    iStep       := 60; // Jump to the next step
```

END_IF;

60:

```
IF NOT StatusWord.12 THEN // Query for completion of the data transfer,
                          // DataTransferOK = FALSE
    // Do other things... // Storage is completed
```

END_IF;

END_CASE

11.16.2 Loading a recipe

The following example code shows how process parameters can be loaded to the internal workpiece recipe.

CASE iStep OF

```

10:
    WorkpieceNo      := 3;      // Load third workpiece recipe
    ControlWord      := 1;      // Begins with the handshake
    iStep            := 20;     // Jump to the next step

20:
    IF StatusWord.12 THEN      // Queries the bit DataTransferOK=TRUE from StatusWord,
                                // Response of the product to transferred data
        ControlWord      := 0;      // Reset of the ControlWord
        iStep            := 30;     // Jump to the next step
    END_IF

30:
    IF NOT StatusWord.12 THEN  // Query for completion of the data transfer,
                                // DataTransferOK = FALSE
        // Do other things...     //Handshake is completed,
                                // Parameters from the third recipe have been taken over into the current process parameters.
    END_IF;
END_CASE

```

12 Operation

NOTICE



In the event of a power failure, for selected products, the gripper jaws remain in their positions and the gripping force of the product stays constant.

The gripper jaws can be opened using the emergency release if the energy supply drops off.

This pertains to the products of the installation sizes GEH6xxxIL-03-B and GED6xxxIL-03-A.

- ▶ Please contact Customer Service if you have any questions.

12.1 Emergency release of GEH6000IL

CAUTION



Risk of injury due to uncontrolled movements

Risk of injury in the event of uncontrolled movement of the product when the power supply is connected.

- ▶ Switch off the power supply to the machine before carrying out any work.
- ▶ Secure the power supply against being switched on unintentionally.
- ▶ Check the machine for any residual energy that may be present.

CAUTION



Risk of injury in case of non-compliance

- ▶ Disconnect the actuator voltage before pressing the emergency release.

The product features an emergency release that can be mechanically opened with an Allen key in the event of a power failure.

- ▶ Remove the protective cap to reach the emergency release.
- ▶ Actuate the emergency release with a corresponding Allen key.
 - Turning counterclockwise opens the jaws (toward the BasePosition).
- ▶ Make sure that the workpiece is secured when opening the product.

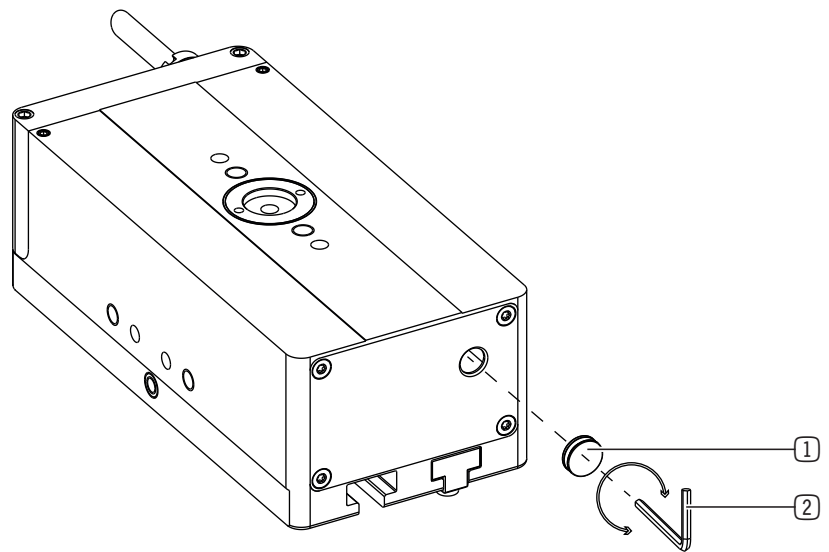

Design size	Wrench size [mm]
GEH6040IL-03-B	2.5
GEH6040IL-31-B	3
GEH6060IL-03-B	2.5
GEH6060IL-31-B	2
GEH6140IL-03-B	3
GEH6180IL-03-B	3

- ① Protective cap
- ② Hexagon socket

INFORMATION



- ▶ Carry out another reference run after any emergency release.
- ▶ Please contact Customer Service if you have any questions.

12.2 Emergency release of GED6000IL

CAUTION



Risk of injury due to uncontrolled movements

Risk of injury in the event of uncontrolled movement of the product when the power supply is connected.

- ▶ Switch off the power supply to the machine before carrying out any work.
- ▶ Secure the power supply against being switched on unintentionally.
- ▶ Check the machine for any residual energy that may be present.

CAUTION



Risk of injury in case of non-compliance

▶ Disconnect the actuator voltage before pressing the emergency release.

The product features an emergency release that can be mechanically opened with an Allen key in the event of a power failure.

- ▶ Remove the protective cap to reach the emergency release.
- ▶ Actuate the emergency release with a corresponding Allen key.
 - Turning counterclockwise opens the jaws (toward the BasePosition).
- ▶ Make sure that the workpiece is secured when opening the product.

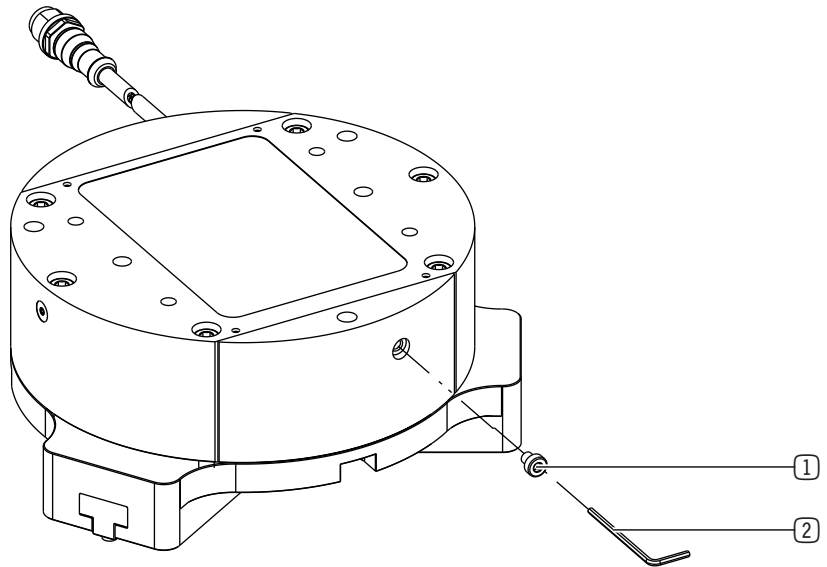

Design size	Wrench size [mm]
GED6040IL-03-A	2.5
GED6040IL-31-A	2
GED6140IL-03-A	3

- ① Protective cap
- ② Hexagon socket

INFORMATION



- ▶ Carry out another reference run after any emergency release.
- ▶ Please contact Customer Service if you have any questions.

13 Gripping force charts

INFORMATION



- ▶ You can find the information in the technical data sheet on our website.
- ▶ Please contact Customer Service if you have any questions.

14 Error diagnosis

Error code	Error	Possible cause	Measure
0x0000	Device is ready for operation.	-	-
0x0001	Motor controller is switched off.	<ul style="list-style-type: none"> Motor controller has not yet been activated. Motor controller has been switched off. Motor controller was switched off for device protection. 	<ul style="list-style-type: none"> Switch on the motor controller.
0x0100	Actuator power supply is not present or is too low.	<ul style="list-style-type: none"> Actuator power supply is not connected Actuator power supply is not sufficient Cable break STO input circuit is interrupted. 	<ul style="list-style-type: none"> Check the actuator power supply. Switch on the STO input circuit.
0x0101	Temperature above maximum permitted temperature.	<ul style="list-style-type: none"> Ambient temperature is too high. Overload of the products. 	<ul style="list-style-type: none"> Provide sufficient ventilation/cooling/ connection. Check that the product moves freely.
0x0102	Max. permitted temperature undershot.	<ul style="list-style-type: none"> Ambient temperature is too low. 	<ul style="list-style-type: none"> Provide an adequate operating temperature.
0x0206	Motion task cannot be executed (CRC error).	<ul style="list-style-type: none"> Internal error 	<ul style="list-style-type: none"> Apply the process data via a handshake. Please contact Customer Service.
0x0300	ControlWord is not plausible.	<ul style="list-style-type: none"> Multiple bits were set in the ControlWord. 	<ul style="list-style-type: none"> In the ControlWord, check that only one bit is set.
	Initial state after gripper restart	<ul style="list-style-type: none"> Modified process data were not taken over. 	<ul style="list-style-type: none"> Apply the process data via a handshake.
0x0301	Positions are not plausible.	<ul style="list-style-type: none"> Transmitted positions are not plausible. Modified process data were not taken over. 	<ul style="list-style-type: none"> Check the transmitted process data. Apply the process data via a handshake.
0x0302	GripForce is not plausible.	<ul style="list-style-type: none"> Transmitted GripForce is not plausible. Modified process data were not taken over. 	<ul style="list-style-type: none"> Check the transmitted process data. Apply the process data via a handshake.
0x0303	DriveVelocity is not plausible.	<ul style="list-style-type: none"> Transmitted DriveVelocity is not plausible. Modified process data were not taken over. 	<ul style="list-style-type: none"> Check the transmitted process data. Apply the process data via a handshake.
0x0304	PositionTolerance is not plausible.	<ul style="list-style-type: none"> Transmitted PositionTolerance is not plausible. Modified process data were not taken over. 	<ul style="list-style-type: none"> Check the transmitted process data. Apply the process data via a handshake.

Error code	Error	Possible cause	Measure
0x0305	Position measuring system not referenced.	<ul style="list-style-type: none"> Position measuring system is not referenced. A reference run is being performed. 	<ul style="list-style-type: none"> ▶ Reference the product. ▶ Wait until the reference run is complete.
0x0306	DeviceMode is not plausible.	<ul style="list-style-type: none"> Transmitted DeviceMode is not plausible. Modified process data were not taken over. 	<ul style="list-style-type: none"> ▶ Check the transmitted process data. ▶ Apply the process data via a handshake.
0x0307	Motion task cannot be executed.	<ul style="list-style-type: none"> Multiple motion tasks in the same direction. <ul style="list-style-type: none"> In DM6x, MoveToWork if ActualPosition > WorkPosition In DM7x, MoveToBase if ActualPosition < BasePosition In DM8x, MoveToWork if ActualPosition > ShiftPosition In DM9x, MoveToBase if ActualPosition < ShiftPosition 	<ul style="list-style-type: none"> ▶ Reset the direction flag. <ul style="list-style-type: none"> ▶ Send the move command again. ▶ Position the product correctly before gripping.
0x0308	WorkpieceNo cannot be selected.	<ul style="list-style-type: none"> Transmitted workpiece number is outside the permitted range. Modified process data were not taken over. 	<ul style="list-style-type: none"> ▶ Check the transmitted process data. ▶ Apply the process data via a handshake.
0x0313	Calculated ShiftPosition exceeded.	<ul style="list-style-type: none"> Start position is not permitted for the selected motion task. 	<ul style="list-style-type: none"> ▶ Move to the BasePosition with DeviceMode 60. ▶ Move to the WorkPosition with DeviceMode 70.
0x0402	Jam	<ul style="list-style-type: none"> Gripper jaws are blocked. Gripper jaws are tensioned incorrectly. 	<ul style="list-style-type: none"> ▶ Check that the product moves freely. ▶ Send a motion task in the opposite direction.
0x0404	Position sensor error	<ul style="list-style-type: none"> Fault of the integrated position sensor 	<ul style="list-style-type: none"> ▶ Reference the product with a homing command. ▶ Please contact Customer Service.
0x0406	Internal error	<ul style="list-style-type: none"> Internal error 	<ul style="list-style-type: none"> ▶ Please contact Customer Service.
0x040B	Internal error	<ul style="list-style-type: none"> Internal error 	<ul style="list-style-type: none"> ▶ Please contact Customer Service.
0x040C	Internal error	<ul style="list-style-type: none"> Internal error 	<ul style="list-style-type: none"> ▶ Please contact Customer Service.
0x040D	Internal error	<ul style="list-style-type: none"> Internal error 	<ul style="list-style-type: none"> ▶ Please contact Customer Service.
0x040E	Internal error	<ul style="list-style-type: none"> Internal error 	<ul style="list-style-type: none"> ▶ Please contact Customer Service.

Error code	Error	Possible cause	Measure
0x040F	Internal error	<ul style="list-style-type: none"> Internal error 	<ul style="list-style-type: none"> ▶ Please contact Customer Service.

15 Table with acyclic data (ISDU)

INFORMATION



IO-Link distinguishes between cyclical process data (PDU) and acyclic data (ISDU).

Access to acyclic data is not arranged very conveniently for all control system and IO-Link master combinations. For this reason, the product can be used without acyclic data. This makes it as easy as possible to control the product.

► Please contact Customer Service if you have any questions.

INFORMATION



► Note that the acyclic data with the following parameters correspond to the reflection of the process data:

- StatusWord, Diagnosis, ControlWord, ActualPosition, TeachPosition, WorkpieceNo, DeviceMode, PositionTolerance, GripForce, DriveVelocity, BasePosition, ShiftPosition, WorkPosition

Index	Name	Data format	Access rights	Values	Description
0x0017 (23)	Firmware version	STRING	Read	-	Firmware version consists of four parts in the following sequence: <ul style="list-style-type: none"> • Communication Firmware <ul style="list-style-type: none"> • Example: <ul style="list-style-type: none"> • Type: SWA000058 • Version: R00 • Application Firmware <ul style="list-style-type: none"> • Example: <ul style="list-style-type: none"> • Type: SWA000059 • Version: P00 • Motor Control Firmware <ul style="list-style-type: none"> • Example: <ul style="list-style-type: none"> • Type: SWA000060 • Version: D00 • Parameters <ul style="list-style-type: none"> • Example: <ul style="list-style-type: none"> • Type: PAR000059_04 • Version: 10030
0x0040 (64)	Status	UINT16	Read	0 - 65535	Parameter to read out the StatusWord.
0x0041 (65)	Diagnosis	UINT16	Read	0 - 65535	Read out of the diagnostic code.
0x0042 (66)	Cycle counter	UINT32	Read	0 to 4294967295	Read out of the total number of cycles.
0x0043 (67)	Temperature	UINT16	Read	0 to 100 °C	Current temperature
0x0044 (68)	ControlWord	UINT16	Read	0 - 65535	Read out the current temperature.
0x0045 (69)	Error code	STRING	Read	-	Read out of the current error state.
0x0046 (70)	Error counter	UINT32	Read	0 to 4294967295	Read out of the number of errors since the restart.
0x0100 (256)	ActualPosition	UINT16	Read	0 to max. jaw stroke of the product [0,01 mm]	Read out the current position of the gripper jaws.

Index	Name	Data format	Access rights	Values	Description
0x0101 (257)	TeachPosition	UINT16	Read	0 to max. jaw stroke of the product [0,01 mm]	Read out of the current transmitted TeachPosition.
0x0102 (258)	WorkpieceNo	UINT8	Read	0 - 32	Read out of the transmitted workpiece number.
0x0103 (259)	DeviceMode	UINT8	Read	1 to 95	Read out of the transmitted travel mode.
0x0104 (260)	PositionTolerance	UINT8	Read	0 to 255	Read out of the transmitted tolerance of the TeachPosition.
0x0105 (261)	GripForce	UINT8	Read	1 to 130 %	Read out of the transmitted gripping force.
0x0107 (263)	DriveVelocity	UINT8	Read	1 to 100 %	Read out of the transmitted movement speed.
0x0108 (264)	BasePosition	UINT16	Read	0 to max. jaw stroke of the product [0,01 mm]	Read out of the transmitted outer jaw position.
0x0109 (265)	ShiftPosition	UINT16	Read	0 to max. jaw stroke of the product [0,01 mm]	Read out of the transmitted toggle position.
0x010A (266)	WorkPosition	UINT16	Read	0 to max. jaw stroke of the product [0,01 mm]	Read out of the transmitted inner jaw position.
0x0120 (288)	NoHomingAt-Startup	UINT8	Read/write	0 to 1	<p>For ISDU 288.0 = 1, the homing bit = 0 after the cold boot.</p> <p>The product is delivered with NoHomingAtStartup = 0.</p> <p>This setting is stored in the product.</p> <p>► When swapping out the product, write the values again.</p> <p>The function is available starting from Application Firmware Version SWA000059_000, see Index 0x0017.</p>

Index	Name	Data format	Access rights	Values	Description
0x0121 (289)	RegripForce	UINT8	Read/write	1 to 100 %	<p>The holding pressure current can be adapted for DeviceModes 65, 74, 84, 94.</p> <p>The function is available starting from Application Firmware Version SWA000059_P00, see Index 0x0017.</p> <p>The holding pressure current is not preset to the maximum possible value when shipped from the factory.</p> <p>The maximum value can be changed via ISDU.</p> <ul style="list-style-type: none"> ▶ Read the current settings in ISDU 289.0. <ul style="list-style-type: none"> • The default (factory) value is around 90. Example: 90% for GEH61XXIL-03-B. ▶ Write the new values to ISDU 289.0. <ul style="list-style-type: none"> • The values can vary between 1% and 100%. ▶ Do not use any amperages that are below the preset value. <p>⇒ This setting is stored in the product.</p> <ul style="list-style-type: none"> ▶ When swapping out the product, write the values again.

Index	Name	Data format	Access rights	Values	Description
0x0122 (290)	ForceReset	UINT8	Read/write	0 to 1	<p>In DeviceModes 63, 64, 73, 74, 84, 85, 95, no unlocking operation is normally carried out.</p> <p>The ForceReset function makes it possible to carry out the unlocking operation.</p> <p>The product is delivered with ForceReset = 0.</p> <ul style="list-style-type: none"> ▶ Set ForceReset = 1 to request the unlocking operation. ⇒ This setting is stored in the product. ▶ When swapping out the product, write the values again. <p>The function is available starting from Application Firmware Version SWA000059_000, see Index 0x0017.</p>

Index	Name	Data format	Access rights	Values	Description
0x0123 (291)	ForceMove	UINT8	Read/write	0 to 1	<p>If in DeviceModes 6x, the ActualPosition is greater than the WorkPosition, MovetoWork is not run and an error is generated (diagnostics 0x307).</p> <p>If in DeviceModes 6x, the ActualPosition is less than the BasePosition, MovetoWork is not run and an error is generated (diagnostics 0x307).</p> <p>The move command can be carried out using the ForceMove function.</p> <p>The product is delivered with ForceMove = 0.</p> <ul style="list-style-type: none"> ▶ Set ISDU 291.0 = 1 to enable the move command. • DeviceMode 6x - Actual-Position > WorkPosition - MovetoWork <p>⇒ This setting is stored in the product.</p> <p>ForceMove = 0 Move command is not executed (diagnostics 0x307).</p> <p>ForceMove = 1 Move command is executed.</p> <ul style="list-style-type: none"> • DeviceMode 7x - Actual-Position < BasePosition - MovetoBase <p>ForceMove = 0 Move command is not executed (diagnostics 0x307).</p> <p>ForceMove = 1 Move command is executed.</p> <p>The product is delivered with ForceMove = 0.</p> <ul style="list-style-type: none"> ▶ When swapping out the product, write the values again. <p>The function is available starting from Application Firmware Version SWA000059_000, see Index 0x0017.</p>

16 Maintenance

NOTICE



Material damage resulting from blowing out with compressed air

Blowing out the product with compressed air can cause malfunctions and pose a risk of accidents.

- ▶ Never purge the product with compressed air.

NOTICE



Material damage caused by unsuitable cleaning materials

Liquid and solvent-based cleaning agents can cause malfunctions and pose a risk of accidents.

- ▶ Do not clean the product with any cleaning agents that are liquid or contain solvents.

NOTICE



Material damage due to leaking lubricant

Excessive lubrication can cause moving machine parts to leak lubricant. This can cause soiling of the machine, the workpiece and the environment.

- ▶ Only use approved or recommended lubricants.
- ▶ Observe the manufacturer information for use of specific lubricants.
- ▶ Adhere to the lubrication interval.
- ▶ Avoid excessive lubrication.
- ▶ Remove leaking lubricant immediately and thoroughly.
- ▶ Replace damaged seals.

Maintenance-free operation of the product is guaranteed for up to **5 million cycles**.

- ▶ Note that the product could become damaged under the following circumstances:

- Dirty environment
 - Improper use and use that does not comply with the performance data
 - Permissible temperature range not observed
- ▶ Even though the product is maintenance-free as mentioned above, perform a regular visual inspection to check for any damage or contamination.
- ▶ Have maintenance work that requires disassembly of the product performed by customer service if possible.
- ⇒ Dismantling and reassembling the product without authorization may result in complications, as special installation equipment is required in some cases. Zimmer GmbH accepts no liability for any resulting malfunctions or damage.

16.1 Testing the STO safety function

In accordance with DIN EN ISO 13849-1, for an application using a control architecture of control category 2, a test of the safety function must be carried out.

In SIL 2, this test is carried out once a year and in SIL 3, once every 24 hours.

► Test the STO safety function in SIL 3 as part of the daily maintenance work.

The figure shows the process for testing the STO safety function.

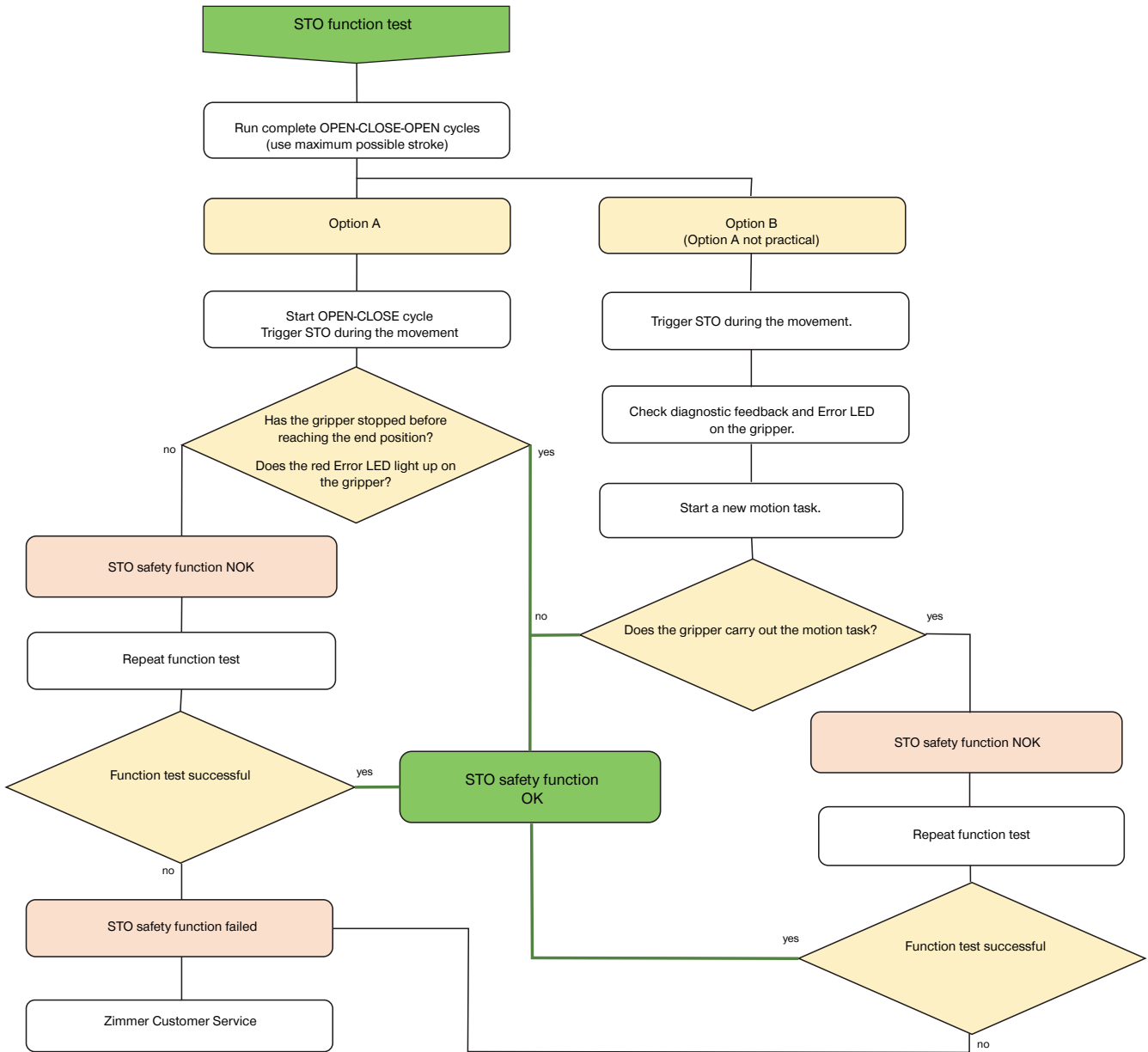

INFORMATION



- Document the result of the function test in accordance with DIN EN ISO 13849-1, Chapter 10.
- Store this documentation in the general maintenance documents.

17 Decommissioning/disposal

INFORMATION



When the product reaches the end of its operational phase, it can be completely disassembled and disposed of.

- ▶ Disconnect the product completely from the power supply.
- ▶ Dispose of the components properly according to the material groups.
- ▶ Comply with the locally applicable environmental and disposal regulations.

18 RoHS declaration

in terms of the EU Regulation 2011/65/EU

Name and address of the manufacturer:

Zimmer GmbH

- 📍 Im Salmenkopf
77866 Rheinau, Germany
- ☎ +49 7844 9138 0
- ✉ info@zimmer-group.com
- 🌐 www.zimmer-group.com

We hereby declare that the incomplete machine described below

- Product designation:** 2-jaw parallel gripper/3-jaw concentric gripper, electric
- Type designation:** GEH6000IL, GED6000IL

conforms to the requirements of the directive in its design and the version we put on the market.

Michael Hoch	Rheinau, Germany, 2020-09-20	
Authorized representative for the compilation of relevant technical documents	(Place and date of issuance)	Martin Zimmer (Legally binding signature) Managing Partner

19 REACH declaration

In terms of the EC Regulation 1907/2006

Name and address of the manufacturer:

Zimmer GmbH

- 📍 Im Salmenkopf
77866 Rheinau, Germany
- ☎ +49 7844 9138 0
- ✉ info@zimmer-group.com
- 🌐 www.zimmer-group.com

REACH stands for **R**egistration, **E**valuation, **A**uthorisation and **R**estriction of **C**hemicals.

A full declaration of REACH can be obtained from the manufacturer due to the duty to notify in accordance with Art. 33 of the REACH regulation (“Duty to communicate information on substances in articles”).

Michael Hoch	Rheinau, Germany, 2020-09-20	
Authorized representative for the compilation of relevant technical documents	(Place and date of issuance)	Martin Zimmer (Legally binding signature) Managing Partner

20 Declaration of Incorporation

In terms of the EU Machinery Directive 2006/42/EC (Annex II 1 B)

Name and address of the manufacturer:

Zimmer GmbH

- 📍 Im Salmenkopf
77866 Rheinau, Germany
- ☎ +49 7844 9138 0
- ✉ info@zimmer-group.com
- 🌐 www.zimmer-group.com

We hereby declare that the incomplete machine described below

- Product designation:** 2-jaw parallel gripper/3-jaw concentric gripper, electric
- Type designation:** GEH6000IL, GED6000IL

conform to the requirements of the Machinery Directive, 2006/42/EC, Article 2g, Annex VII.b – Annex II.b, in its design and the version we put on the market.

Basic health and safety requirements:

No. 1.1.2, No. 1.1.3, No. 1.1.5, No. 1.3.2, No. 1.3.4, No. 1.3.7, No. 1.3.9, No. 1.5.1, No. 1.5.2, No. 1.5.4, No. 1.6.4, No. 1.7.1, No. 1.7.4

A full list of applied standards can be obtained from the manufacturer.

We also declare that the specific technical documents were produced in accordance with Annex VII Part B of this Directive. We undertake to provide the market supervisory bodies with electronic versions of special documents for the incomplete machine through our documentation department, should they have reason to request them.

The incomplete machine may only be commissioned if it has been ascertained, if applicable, that the machine or system in which the incomplete machine is to be installed satisfies the requirements of Directive 2006/42/EC on Machinery and an EC Declaration of Conformity has been drawn up in accordance with Annex II 1 A.

Kurt Ross

Authorized representative for the compilation of relevant technical documents

Rheinau, Germany, 2021-06-04

(Place and date of issuance)



Martin Zimmer
(Legally binding signature)
Managing Partner

21 Declaration of Conformity

As defined by the EC Directive 2014/30/EU on electromagnetic compatibility

Name and address of the manufacturer:

Zimmer GmbH

📍 Im Salmenkopf
77866 Rheinau, Germany
☎ +49 7844 9138 0
✉ info@zimmer-group.com
🌐 www.zimmer-group.com

We hereby declare that the products described below

Product designation: 2-jaw parallel gripper/3-jaw concentric gripper, electric
Type designation: GEH6000IL, GED6000IL

conform to the requirements of the Electromagnetic Compatibility Directive 2014/30/EU in its design and the version we put on the market.

The following harmonized standards have been used:

DIN EN ISO 12100	Safety of machinery - General principles for design - Risk assessment and risk reduction
DIN EN 61000-6-3	EMC Generic standard, Emission standard for residential, commercial and light-industrial
DIN EN 61000-6-2	EMC Generic standard, Emission standard for industrial environments
DIN EN 61000-6-4	EMC Generic standard, Immunity for industrial environments

A full list of applied standards can be obtained from the manufacturer.

Kurt Ross
Authorized representative for the compilation of relevant technical documents

Rheinau, Germany, 2021-06-04
(Place and date of issuance)



Martin Zimmer
(Legally binding signature)
Managing Partner